

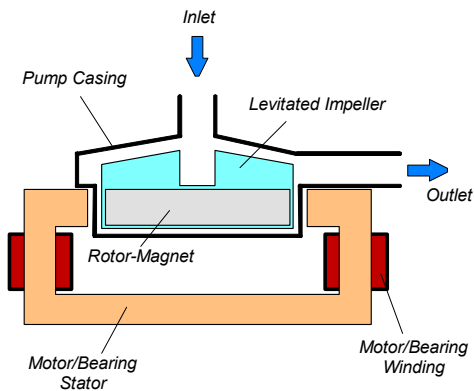
# PuraLev® Life Science Integrated Pump Series



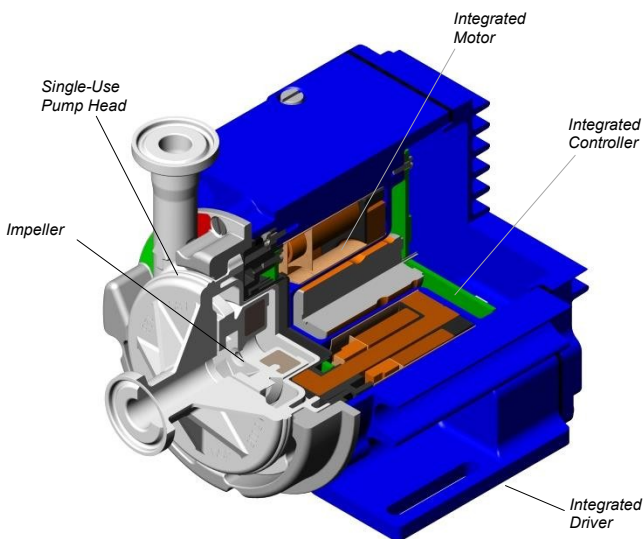
## PuraLev® i100SU (Single-Use)

2 bar	(29 psi)
17 liters/min	(4.5 gallons/min)

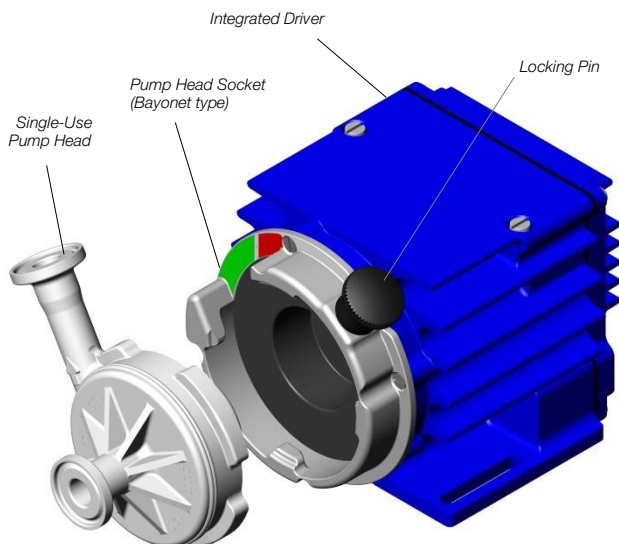
Low Shear Design - High Cell Viability



**Figure 1:** Schematic of the main elements of the MagLev centrifugal pump



**Figure 2:** Integrated MagLev pump driver with single-use pump head



**Figure 3:** Single-use pump head concept

## INTRODUCTION

Levitronix® has developed a revolutionary pump that has no bearings to wear out or seals to break. Based on the principles of magnetic levitation, the pump's impeller is suspended, contact-free, inside a sealed casing and is driven by the magnetic field of the motor (Figure 1). The impeller and casing are both fabricated from biocompatible (FDA, USP-VI, BSE/TSE and Animal free) gamma sterilizable polypropylene (PP) and together they make up the disposable pump head. A simple and intuitive exchange of the single use pump head is achieved with a bayonet socket type mounting procedure (see Figure 6). Flow rate or pressure is precisely controlled by electronically regulating the rotor speed, which eliminates any pulsation. With the lack of mechanical bearings plus the self-contained pump head design, the risk of contamination is drastically reduced. The absence of narrow gaps between the impeller and pump casing, plus the low-shear pump design allows the gentle pumping of sensitive liquids. The pump housing is fabricated with Triclamp fittings and can be easily inserted and removed with an intuitive bayonet socket. The controller and the motor are integrated into the driver housing (see Figure 2), hence cabling effort is reduced.

## SYSTEM BENEFITS

- Low shear-forces.
- Reduced risk of contamination due to the self-contained design with magnetic bearings.
- No particle generation.
- No over-pressure situations (compared to roller pumps).
- No narrow gaps between the impeller and pump casing where bacteria could be entrapped.
- Pump head can be gamma sterilized.
- Biocompatibility of wet materials: FDA, USP-VI, Animal/BSE/TSE free
- Bayonet socket design for easy and intuitive exchange of disposable pump head (see Figure 6).
- Small size.
- Dry running capability.
- Proven technology in the medical (disposable blood pumps) and semiconductor (high-purity pumps) industries.
- High flow capability with compact design.
- Pulsation free.

## APPLICATIONS

- Pumping of shear-sensitive liquids and cells.
- Bioprocessing (for example perfusion).
- Recirculation and transfer applications in bioreactors.
- Filtration.

## SYSTEM CONFIGURATION – “STAND-ALONE”

Figure 7 and Figure 12 illustrate a “Plug and Play” stand-alone system with integrated user panel and buttons to set the speed manually. The driver also contains a PLC interface for remote speed control by analog and digital signals. Various accessories are available like a desktop power supply with relevant power cable and signal cables to connect to the PLC.

## SYSTEM CONFIGURATION – “EASYCONNECT”

The “EasyConnect” models (see Figure 10 and Figure 14) with according cable accessories are designed to realize various interface configurations with minimal setup effort.

Two Fieldbus connectors (IN and OUT) allow to setup arrays of multiple pumps. Therefore, serial pumping configurations as shown in Figure 11 can be realized. The Fieldbus interface allows remote control over a PC, a user panel or other devices with Modbus protocol.

The PLC interface allows not only remote control by analog/digital signals but also connections of external sensors hence enabling for example a precise flow or pressure control (see notes below).

## SYSTEM CONFIGURATION – “OEM”

The “OEM” models are designed for a compact integration with one integrated driver cable containing all available interface signals (see Figure 8 and Figure 16). Basically all configurations of the “EasyConnect” models are possible allowing the users with integration capabilities to adapt the cable to their needs.

## PROCESS CONTROL WITH FEEDBACK SENSORS

Together with an external sensor, process parameters like flow or pressure can be controlled or monitored as shown in Figure 8.

Precise ultrapure flow control systems can be realized with the pump system in combination with LEVIFLOW® flowmeters. Levitronix® provides either turnkey solutions for closed loop flow control or helps to design your own flow control system. Experience has been gained with a wide range of applications.

The versatility of Levitronix® flow control systems goes far beyond the capabilities of simple flow controllers. In addition to the flow control function, the Levitronix® control firmware comes with several condition monitoring features to monitor the integrity of the fluid circuit. Levitronix® flow control systems can generate alarms for preventive filter exchange, no-flow conditions or line clogging. Dynamic Condition Trending (DCT) enables failure prediction and scheduling of preventive maintenance.

## ATEX / IECEx SYSTEM CONFIGURATION

An ATEX / IECEx certified driver (OEM model only) together with the pump head allows installation within an ATEX Zone 2 area (see Figure 9). An Ex conform solution is needed for the motor cables to leave the ATEX area. One option is an ATEX certified cable sealing system as listed in Table 3 (see Pos. 11).

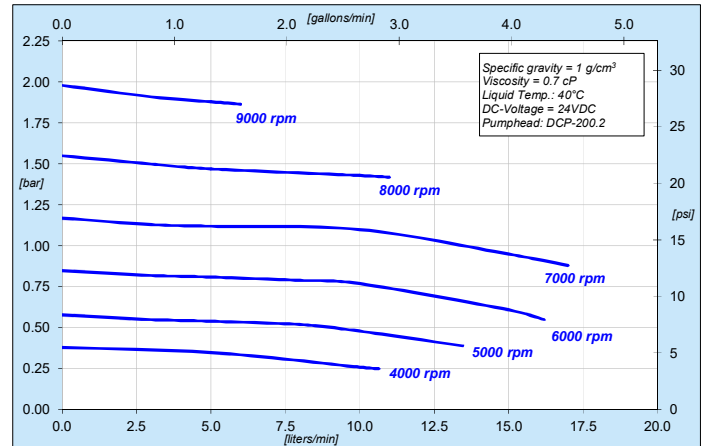


Figure 4: Pressure/flow curves for aqueous liquids (similar to water)

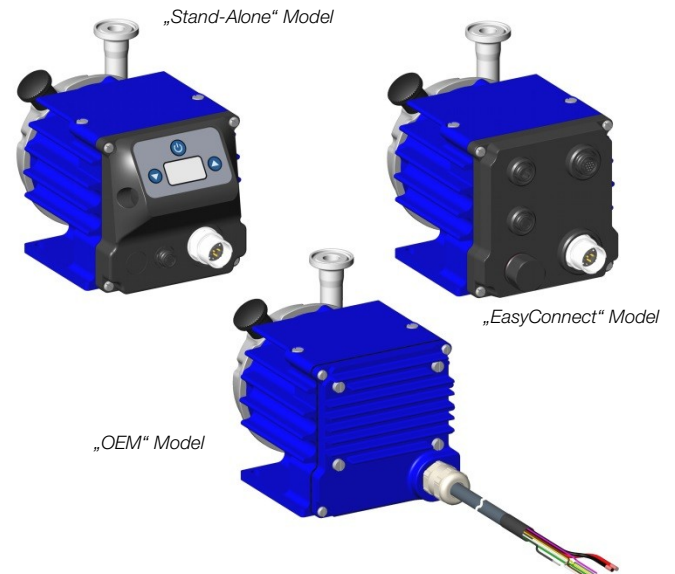


Figure 5: Pump system models

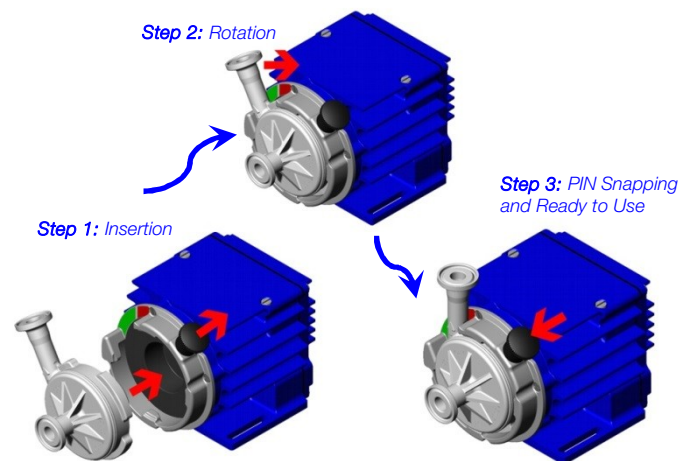
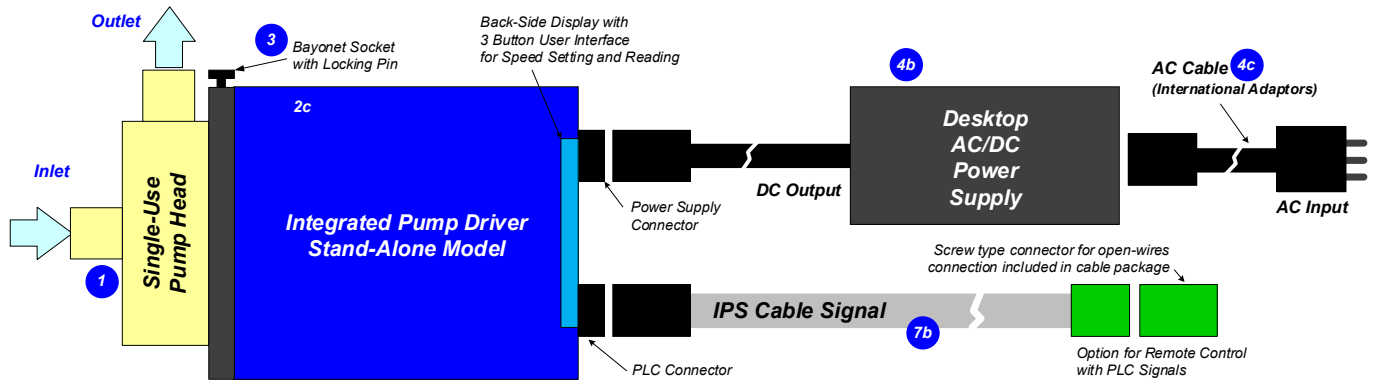


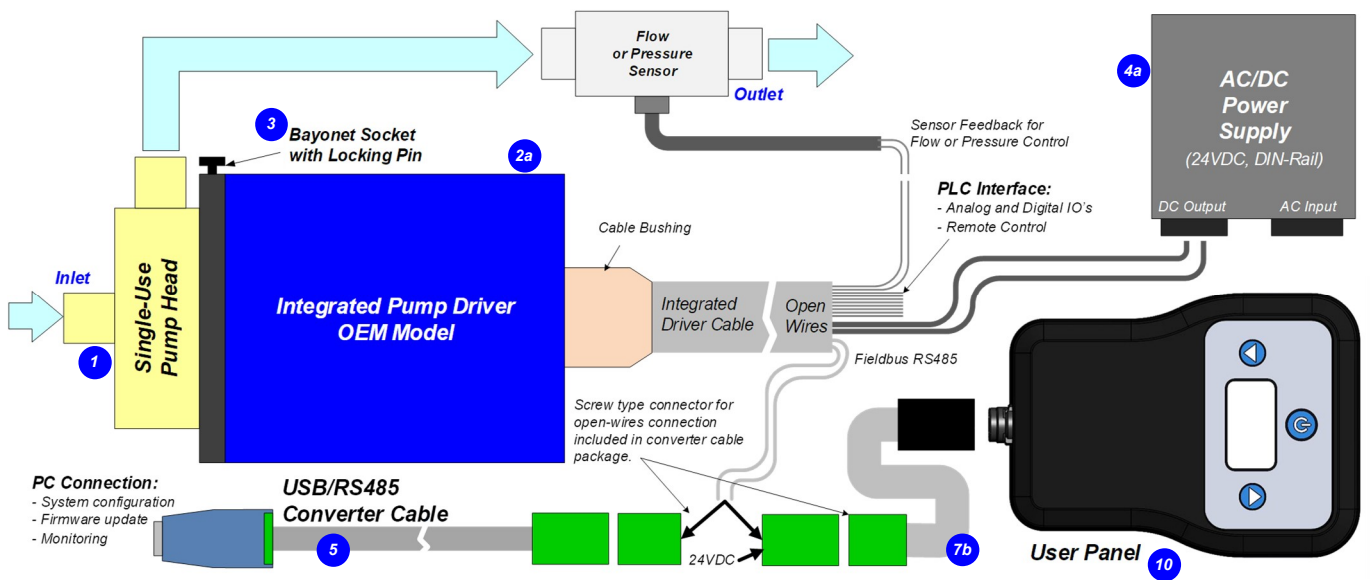
Figure 6: Intuitive 3-step pump head mounting procedure with bayonet type socket (PHS-i100.1)



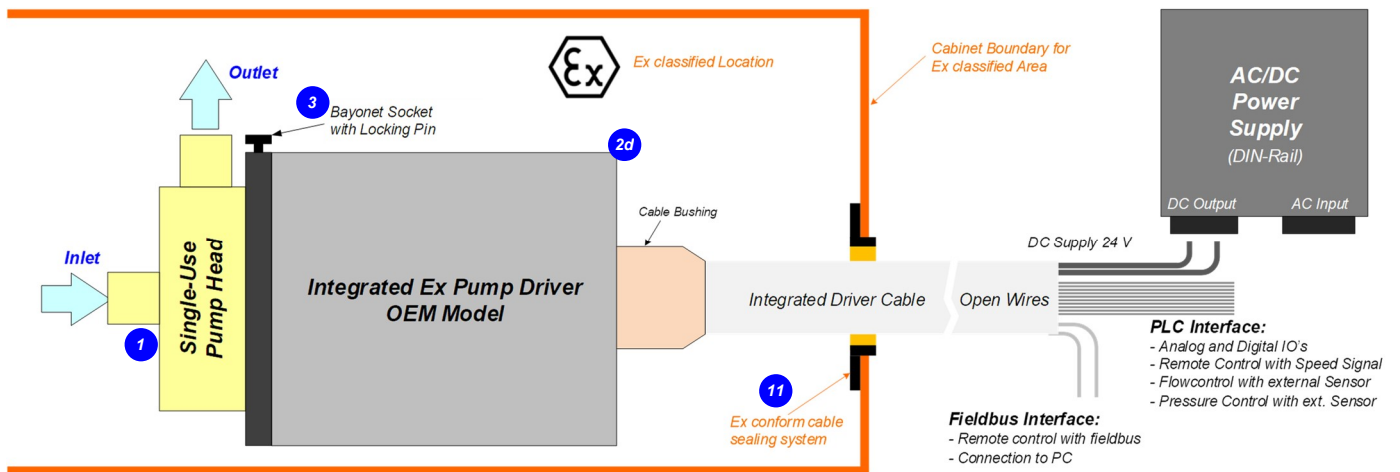
# SYSTEM CONFIGURATIONS



**Figure 7:** Standard "Stand-Alone" system configuration with main accessories  
(See section "Order Information" for details to numbered components and other options.)

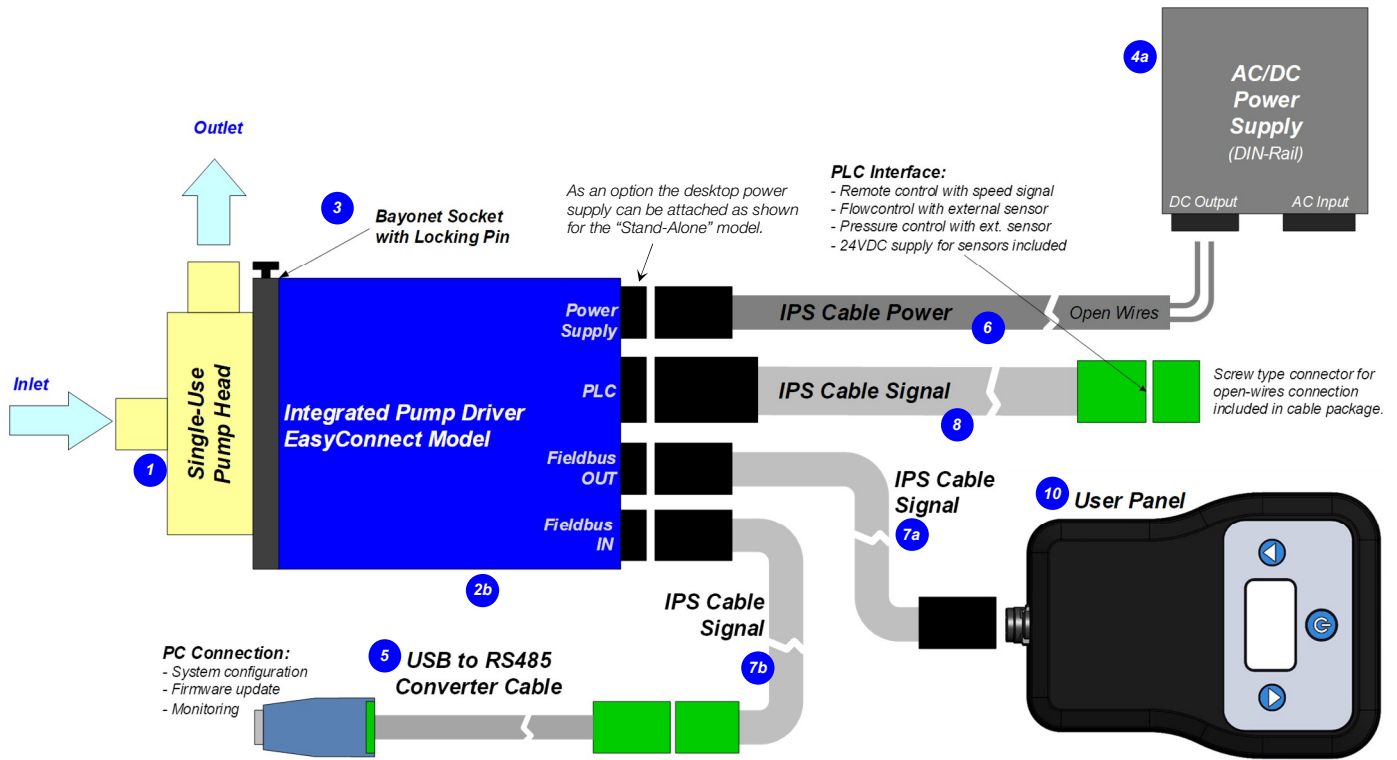


**Figure 8:** Standard "OEM" system configuration  
(See section "Order Information" for details to numbered components and other options.)

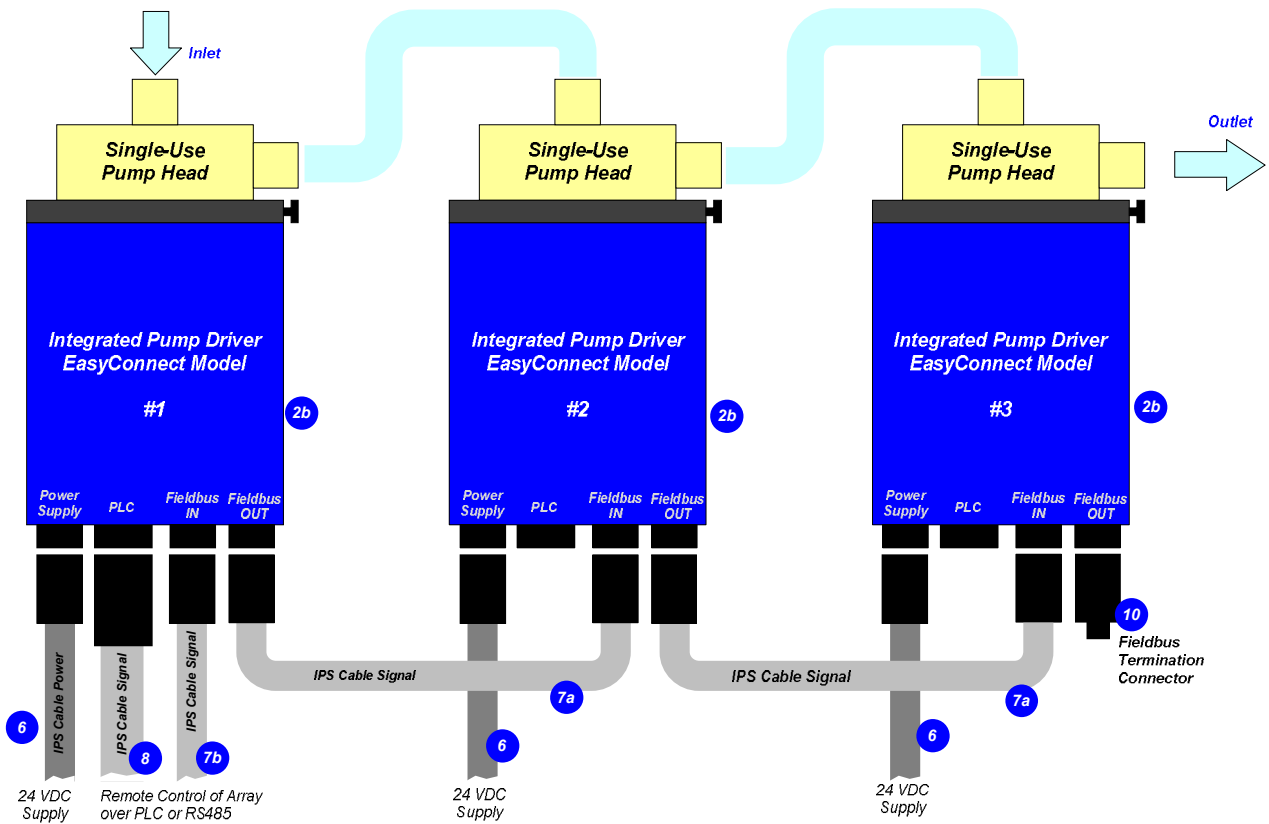


**Figure 9:** ATEX/IECEx "OEM" configuration  
(See section "Order Information" for details to numbered components and other options.)

# SYSTEM CONFIGURATIONS

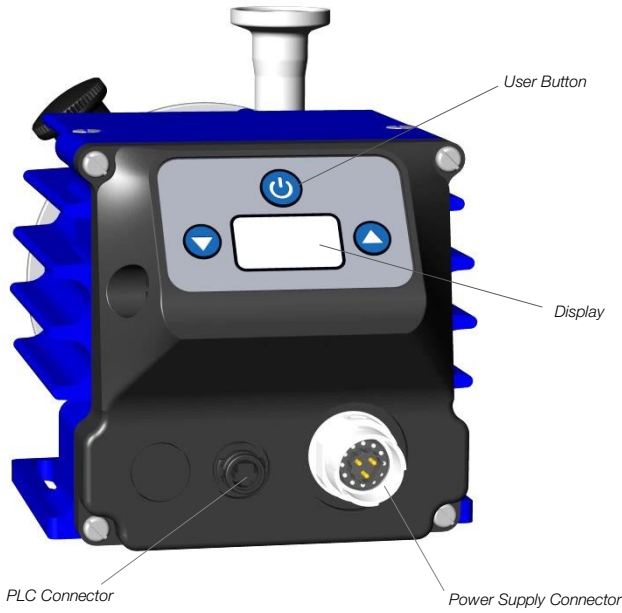


**Figure 10:** Standard "EasyConnect" system configuration with main accessories  
(See section "Order Information" for details to numbered components and other options.)



**Figure 11:** Serial pumping configuration with "EasyConnect" models  
(See section "Order Information" for details to numbered components and other options.)

# MODEL DESCRIPTION – STAND-ALONE



Interface	PIN Name	Description	Standard Designation	Hardware Specification
Power Supply	P+	+ 24 VDC	Supply	Voltage: 24 VDC Power: 110 W
	P-	Power Input Ground / Earth		
	NC	Not connected.		
PLC 6	Ain	Analog Input (Current Input)	Remote Speed	Analog current input: 4 – 20 mA (450 Ohm shunt input, no galvanic isolation)
	Ain_GND	Analog In. GND	--	Reference for Ain
	Dout	Digital Output 1	Status	Open drain, max. 24V, 100mA Reference ground is GND
	GND	Analog Ground	--	Reference for Dout
	Din1	Digital Input 1	Enable (Reset)	Galvanic separation with optocoupler 2.2 kΩ input resistance, 5-24V for active input
	Din_COM	Com. Digi. Input	--	Reference for digital input.
Display and Buttons	--	Display	Speed and Status Display	--
	--	Up/Down	Setting speed	--
	--	On/Off	Enable/Disable	--

Figure 12: Interface specifications of standard "Stand-Alone" model

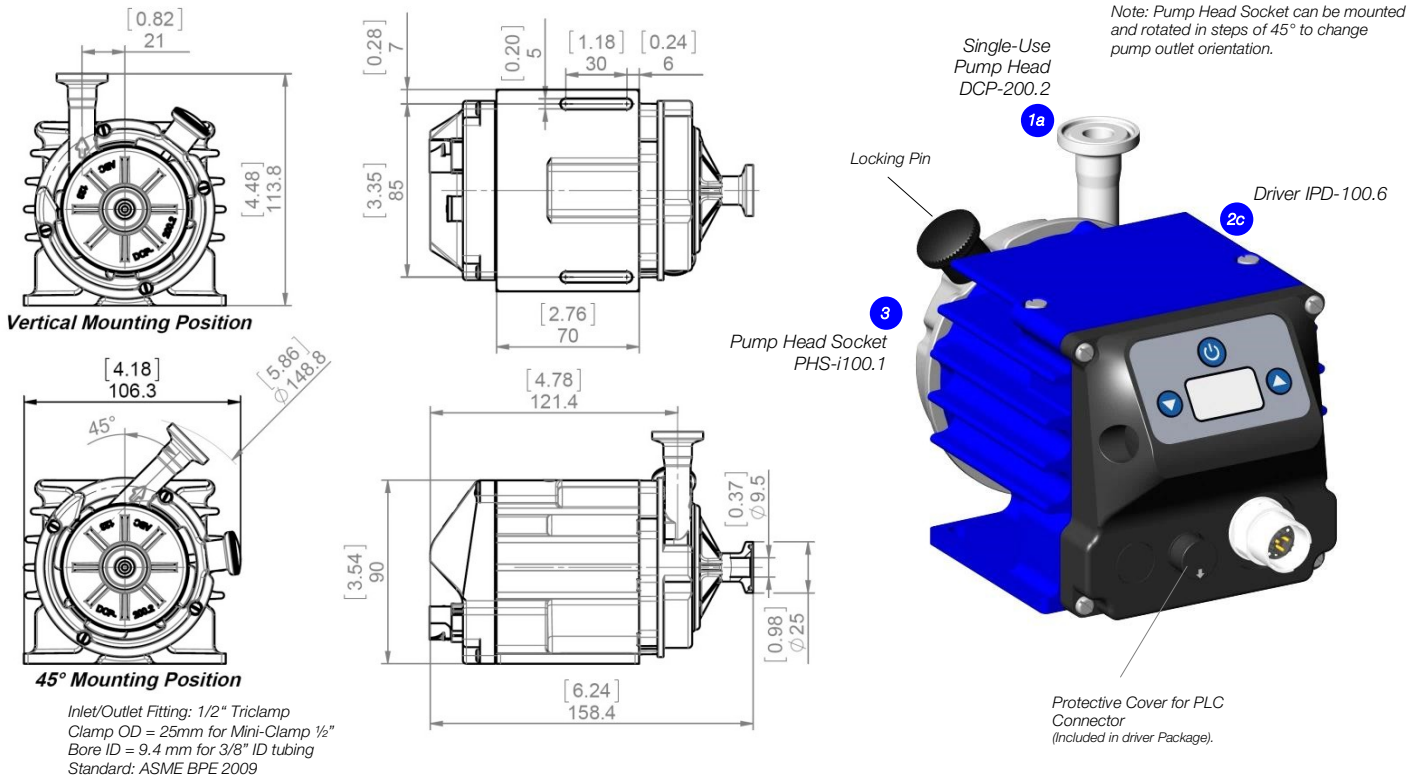
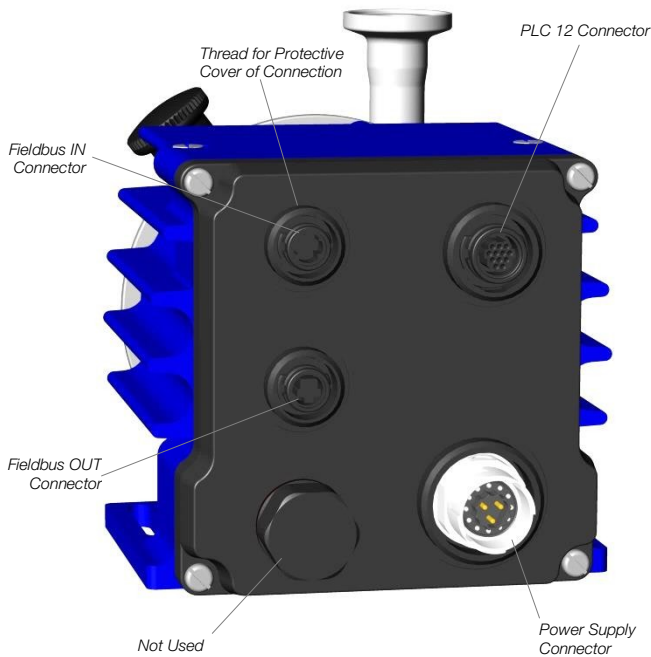


Figure 13: Basic dimensions and description of standard "Stand-Alone" model (Driver IPD-100.6 with pump head socket PHS-i100.1 and single-use pump head DCP-200.2)

# MODEL DESCRIPTION – EASYCONNECT



Connector	PIN Name	Description	Standard Designation	Hardware Specification
Power Supply	P+	+ 24 VDC	Supply	Voltage: 24 VDC
	P-	Ground / Earth		Power: 110 W
	NC	Not connected.	--	--
PLC 12	Dout1	Digital Output 1	Status	Open drain, max. 24V, 100mA
	Dout2	Digital Output 2	Error	Reference ground is GND
	Din1	Digital Input 1	Enable (Reset)	Galvanic separation with optocoupler
	Din2	Digital Input 2	Process Mode	2.2 kΩ input resistance, 5-24V for active input
	Din_COM	Com. Digi. Input	--	Reference for digital input.
	Ain1	Analog Input 1 (Current Input)	Actual Process Value	Analog current input: 4 – 20 mA (450 Ohm shunt input, no galvanic isolation)
	Ain2	Analog Input 2 (Voltage Input)	Reference Value	Analog voltage input: 0 – 10V (7.9 kOhm, no galvanic isolation)
	Ain_GND	Analog In. GND	--	Reference for Ain1 and Ain2
	Aout1	Analog Output (Voltage Output)	Actual Speed	0 – 10V (no galvanic isolation) GND is reference
	GND	Analog Ground	--	Reference for Aout1, Dout1, Dout2 and Pout
Fieldbus OUT	Supply	Output 24 VDC	Supply Output	For supply of external devices (e.g. sensors)
	NC	Not connected.	--	--
	GND	Ground	--	Reference for Pout.
	Pout	Output 24 VDC	Supply Output	For supply of external devices (user panels)
Fieldbus IN	RS485+	RS485 +	Fieldbus	Modbus protocol
	RS485-	RS485 -		
	Internal	Internal Bus	Do not connect	Internal bus needed to connect pumps for serial pumping.
	Internal	Internal Bus	Do not connect	
	GND	Ground	--	--
Fieldbus IN	NC	Not connected.	--	--
	RS485+	RS485 +	Fieldbus	Modbus protocol
	RS485-	RS485 -		
	Internal	Internal Bus	Do not connect	Internal bus needed to connect pumps for serial pumping.
	Internal	Internal Bus	Do not connect	

Figure 14: Interface specifications of standard "EasyConnect" model

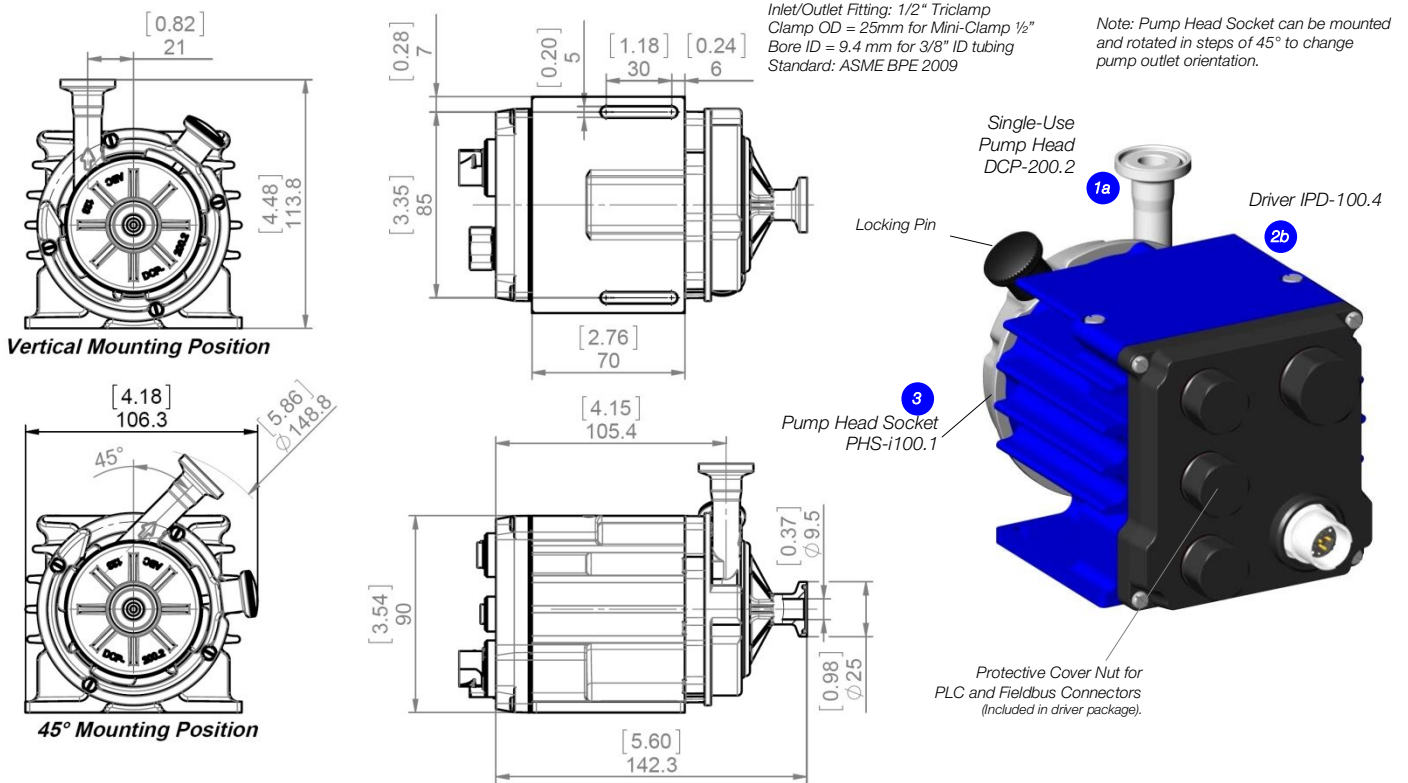
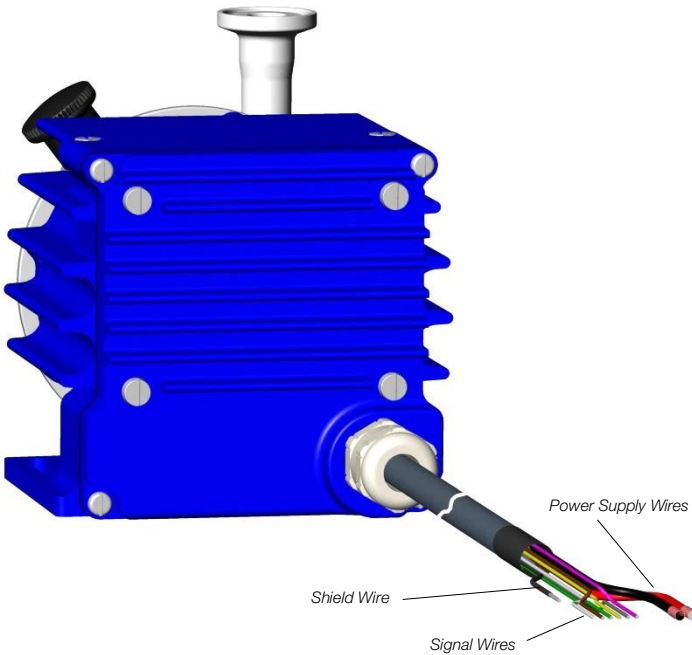


Figure 15: Basic dimensions and description of standard "EasyConnect" model

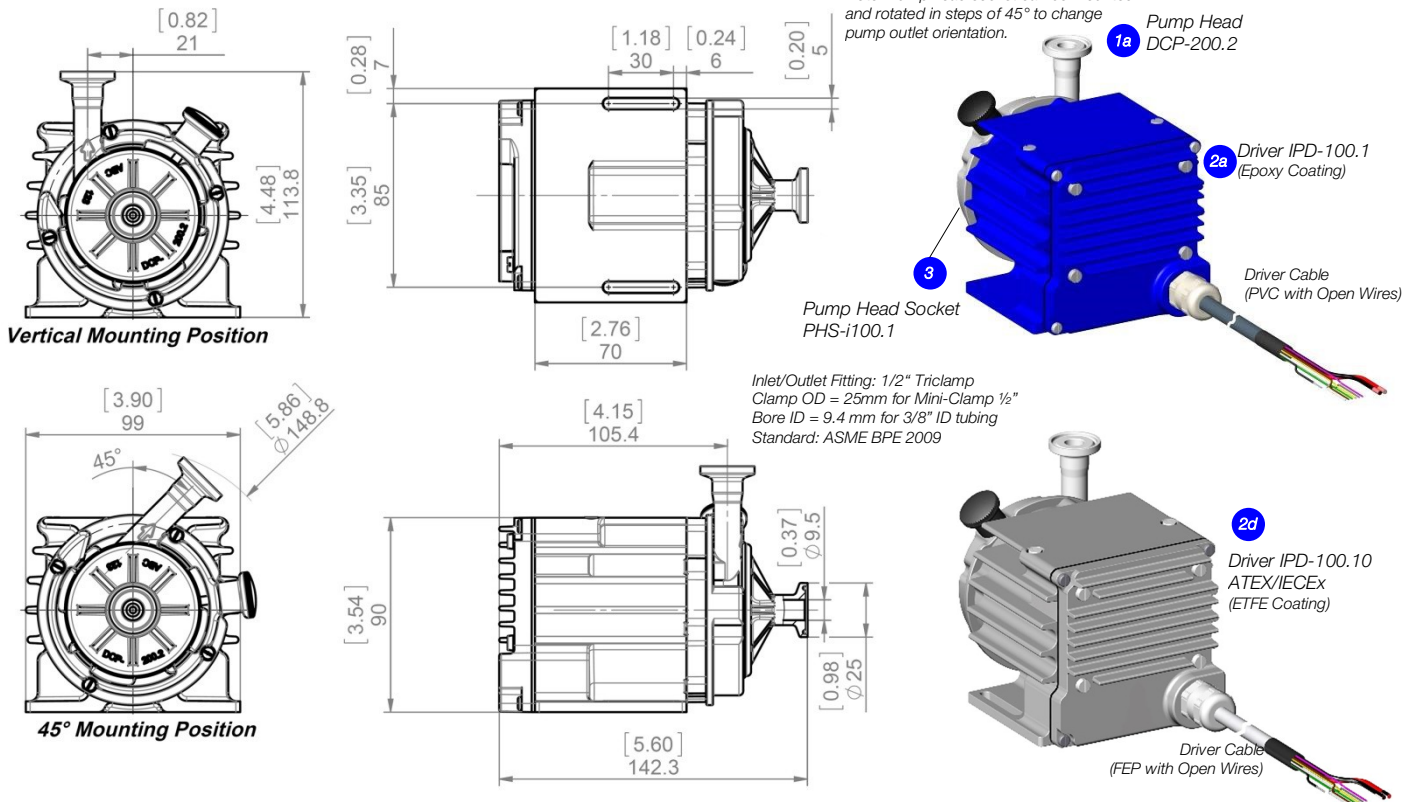
# MODEL DESCRIPTION - OEM



Wire Name	Description	Standard Designation	Hardware Specification
P+	+ 24 VDC	Supply	Voltage: 24 VDC P- to be connected to earth
P-	Power Input Ground / Earth		
Ain1	Analog Input 1 (Current Input)	Actual Process Value	Analog current input: 4 – 20 mA (450 Ohm shunt input, no galvanic isolation)
Ain2	Analog Input 2 (Voltage Input)	Reference Value	Analog voltage input: 0 – 10V (7.9 kOhm, no galvanic isolation)
Ain_GND	Analog Input Ground	--	Reference for Ain1 and Ain2
Din1	Digital Input 1	Enable (Reset)	Galvanic separation with optocoupler 2.2 kΩ input resistance, 5-24V for active input
Din2	Digital Input 2	Process Mode	
Din_COM	Common Digital Input	--	--
Aout1	Analog Output (Voltage Output)	Actual Speed	0 – 10V (no galvanic isolation) GND is reference
Dout1	Digital Output 1	Status	Open drain, max. 24V, 100mA
Dout2	Digital Output 2	Error	Reference ground is GND
GND	Analog Ground	--	Reference for Aout1, Dout1 and Dout2
RS485+	RS485 +	Fieldbus	Modbus protocol
RS485-	RS485 -		
Internal	Internal Bus	Do not connect	--
Internal	Internal Bus	Do not connect	--
Shield	Shielding	Shielding	To be connected to earth (see wire No. 2, P-)

**Figure 16:** Interface specifications of standard "OEM" model

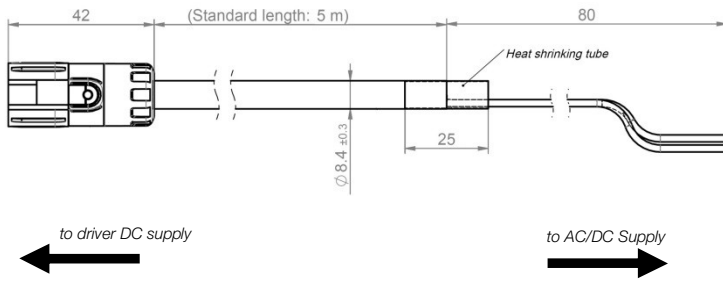
Note 1: Power supply wire cross-section is 1.5 mm<sup>2</sup> and for signal wires 0.14 mm<sup>2</sup>      Note 2: For more detailed description of interfaces consult user manual



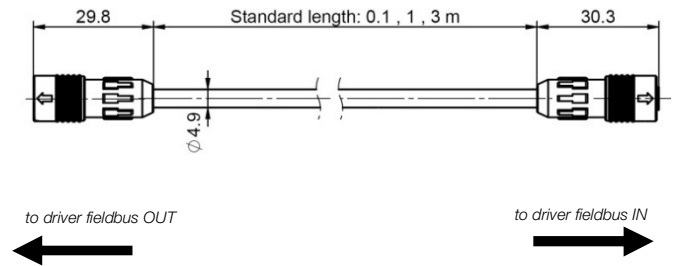
**Figure 17:** Basic dimensions and description of standard "OEM" model



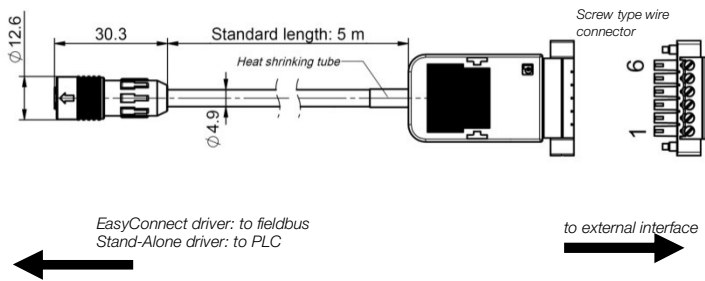
**6** IPS Cable Power ICP-2.1 (for EasyConnect and Stand-Alone drivers)



**7a** IPS Cable Signal ICS-1.1 (for EasyConnect drivers)



**7b** IPS Cable Signal ICS-1.2 (for EasyConnect and Stand-Alone drivers)



**8** IPS Cable Signal ICS-2.1 (for EasyConnect drivers)

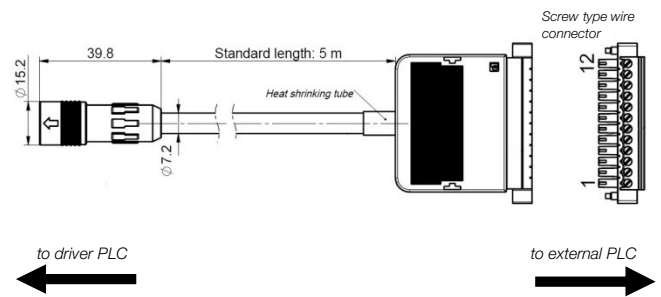


Figure 18: Basic dimensions and specifications of standard cables

# ORDER INFORMATION

System Name	Article #	Pump Head Socket	Driver	Note
PLD-i100SU.1	100-91054	PHS-i100.1	IPD-100.1-50-02	OEM - Driver, 5 m PVC cable with open wires, pump head socket.
PLD-i100SU.5	100-91511	PHS-i100.1	IPD-100.10-50-02	OEM - ATEX/IECEx - 5 m FEP cable with open wires, pump head socket.
PLD-i100SU.2	100-91095	PHS-i100.1	IPD-100.4-02	EasyConnect - Driver with interface connectors, pump head socket.
PLD-i100SU.3	100-91055	PHS-i100.1	IPD-100.6-02	Stand-Alone - Driver with integrated user panel, pump head socket.

**Table 1:** Standard driver system configurations

Pos.	Component	Article Name	Article #	Characteristics	Value / Feature
1a 1b	Single-Use (SU) Pump Heads	DCP-200.2 (Triclamp)	100-90734	Impeller / Pump Housing Housing Sealing In-/Outlet Fittings	Polypropylene (FDA, USP Class VI, BSE/TSE/Animal free) Infrared welding Triclamp 1/2" or Barb 1/2" for tubing with typical ID 3/8"
1c 1d		DCP-200.3 (Barb)	100-90792	Max. Flow Max. Diff.-Pressure Max. Viscosity	17 liters/min / 4.5 gallons/min 2 bar / 29 psi < 20 cP
		DCP-200.2-G25	100-91078	Wet Pump Volume/Surface	24 ml / 150 cm <sup>2</sup> with Triclamp and 25 ml / 150 cm <sup>2</sup> with Barb fittings
		DCP-200.3-G25 (Gamma Irradiated with Dosage ≥ 25 kGy)	100-91122	Max. Liquid Temp.	60°C / 140°F
				Applicable Sterilization	Gamma radiation up to 40kGy
1e	SU Pump Head with Sterile Fittings	DCP-200.3-SF1-G25	100-91233	Pump Type (A) / Tubing (C) Sterile Fittings (B) Fitting Compatibility Applied Gamma Dosage	DCP-200.3 (Barb) / Silicone AseptiQuik® G from CPC® with part # AQG17008 <sup>3</sup> Various sizes and types including autoclavable versions available at CPC® ≥ 25 kGy
2a	Integrated Pump Driver ("OEM Model")	IPD-100.1-50-02	100-10070	Voltage, Power Housing / Cable Interfaces Standard Firmware	24 VDC ±10%, 110 W Epoxy coated Alu., IP65 <sup>1</sup> / PVC jacket, open wires, cable length 5 m PLC and RS485 with Modbus protocol (see Figure 16 for details) G3.48
2b	Integrated Pump Driver ("EasyConnect" Model)	IPD-100.4-02	100-10111	Housing Interfaces Standard Firmware	Epoxy coated Aluminum, PP for bottom lid, IP65 2x Fieldbus RS485 with Modbus protocol, PLC and power supply G3.48 <sup>2</sup>
2c	Integrated Pump Driver ("Stand-Alone" Model)	IPD-100.6-02	100-10106	Housing Interfaces Standard Firmware	Epoxy coated Aluminum, PP for bottom lid, IP65 User panel with 3 user buttons, PLC and power supply G3.48
2d	Integrated Pump Driver ("OEM ATEX" Model)	IPD-100.10-50-02	100-10201	Housing / Cable Interfaces ATEX / IECEx Marking Standard Firmware	ETFE coated Alu., IP65 <sup>1</sup> / FEP jacket, open wires, cable length 5 m PLC and RS485 with Modbus protocol (see Figure 16 for details) CE Ex II 3G Ex ec h mc IIC T4 Gc / CE Ex II 3D Ex h to IIC T90°C Dc G3.48
3	Pump Head Socket	PHS-i100.1	100-91053	Mounting Type Material Assembly Screws	Bayonet type with locking pin Anodized Aluminum 4 pcs M3 x 8 mm (Stainless Steel, INOX A4)

**Table 2:** Specification of standard components

Note 1: Designed and tested for IP67. Note 2: Special firmware for serial pumping as one unit available on request. Note 3: CPC® and AseptiQuik® are registered marks of the Colder Product Company

Pos.	Component	Article Name	Article #	Characteristics	Value / Feature
4a	AC/DC Power Supply	TSP 180-124 (Traco)	100-40018	Voltage Output / Input Basic Dimensions Certification or Standards	24 VDC with 180 W / 85 – 132 and 187 – 264 VAC (autoselect) 110 x 110 x 54 mm (mountable on DIN rail 35 mm) UL/cUL, CB, Semi F47
4b	Desktop AC/DC Power Supply	GST160A24-R7B IC915	100-40020	Voltage Output / Input Basic Dimensions Safety Approvals Note	24VDC, 160W / 85 – 264 VAC, 47-63 Hz 175 x 72 x 35 mm UL60950-1, CSA C22.2, TUV EN60950-1 Connector for direct connection to power supply of driver with cable length 1.2 m.
4c	AC Mains Cables (for Desktop power supply 5b)	AMC-1.1 (2m) AMC-1.2 (2.5m) AMC-1.3 (2.5m) AMC-1.4 (2.5m) AMC-1.5 (2.5m)	190-10331 190-10332 190-10333 190-10334 190-10335	Approvals and Country Approvals and Country Approvals and Country Approvals and Country Approvals and Country Cable Specifications	UL, cUL, US, Canada CB, Germany, Denmark, Norway, Finland, Belgium, Netherl., Sweden, Austria PSE, Japan Switzerland CE, United Kingdom Black color, ROHS
5	USB to RS485 Adaptor-TR Isolated	YN-485I-TR	100-30392	Structure/Design  Purpose	USB connector (A) with termination resistor and cable (2m) with connector pair (B and C) for external RS485 wire connection. Magnetically isolated. Cable length is 2m. Included is a USB space saver cable (D).  Communication over fieldbus of driver with PC
6	IPS Cable Power 2 Wires	ICP-2.1-50 (5 m)	190-10370	Cable Material / Wires Connection In / Connection Out Main Purpose	PVC jacket / 2x 1.5 mm <sup>2</sup> Open wires / Circular Intercontec type to driver Connection of power supply to "Stand-Alone" and "EasyConnect" drivers
7a	IPS Cable Signal 6 Wires	ICS-1.1-02 (0.2 m) ICS-1.1-10 (1 m) ICS-1.1-30 (3 m)	190-10381 190-10344 190-10345	Cable Material / Wires Connection In / Connection Out Main Purpose	PVC jacket / 6x 0.08 mm <sup>2</sup> and shielding Circular Hirose type / Circular Hirose type Fieldbus connection between "EasyConnect" drivers (e.g. multi-pump arrays)
7b	IPS Cable Signal 6 Wires	ICS-1.2-50 (5 m)	190-10346	Cable Material / Wires Connection In / Connection Out Main Purpose	PVC jacket / 6x 0.08 mm <sup>2</sup> and shielding Connector with screw type plug for open wire connection / Circular Hirose type Fieldbus connection to "EasyConnect" drivers and to PLC of "Stand-Alone" drivers.
8	IPS Cable Signal 12 Wires	ICS-2.1-50 (5 m)	190-10347	Cable Material / Wires Connection In / Connection Out Main Purpose	PVC jacket / 12x 0.14 mm <sup>2</sup> and shielding Connector with screw type plug for open wire connection / Circular Hirose type General connection to PLC of "EasyConnect" drivers.
9	Fieldbus Termination Connector	FTC-1.1	190-10348	Materials Main Purpose	PPS for connector housing and FPM for sealing. Termination of fieldbus.
10	User Panel	LUI-B.1-01	100-30448	Interface / Housing Rating Standard Firmware	RS485 / IP65 A3.00
11	ATEX Cable Sealing System	ACS-A.1 (Roxtec)	100-90292	Sleeve (A) and Gasket (B) Frame (C) 2x Cable Module (D)	Stainless Steel and EPDM Roxylon (EPDM rubber) Roxylon (EPDM rubber)  Note: Lubricant (E) and measurement plates (F) are included.

**Table 3:** Specification of accessories

Note 1: Designed and tested for IP67.

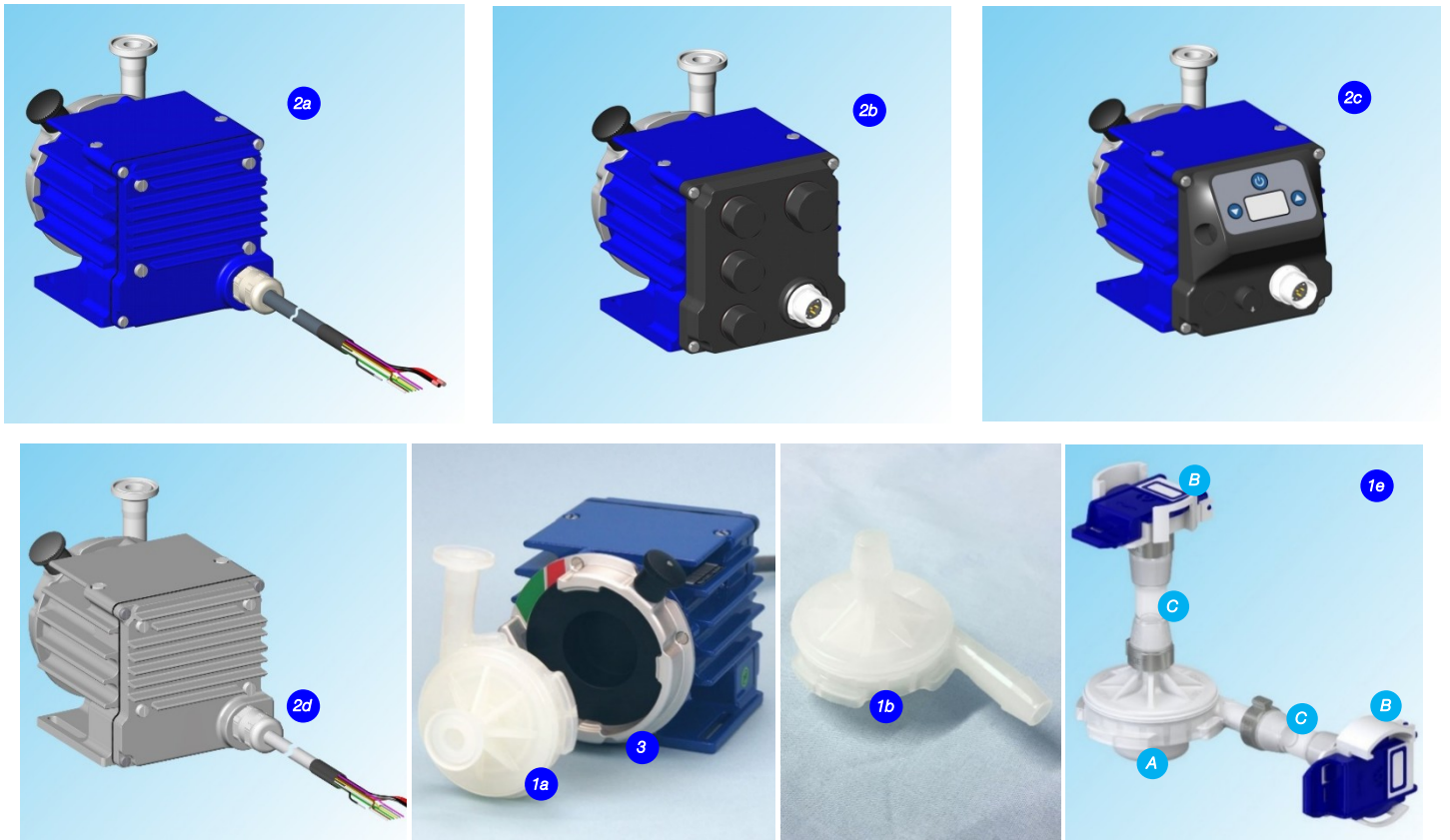


Figure 19: Pump systems with standard components



Figure 20: General standard accessories

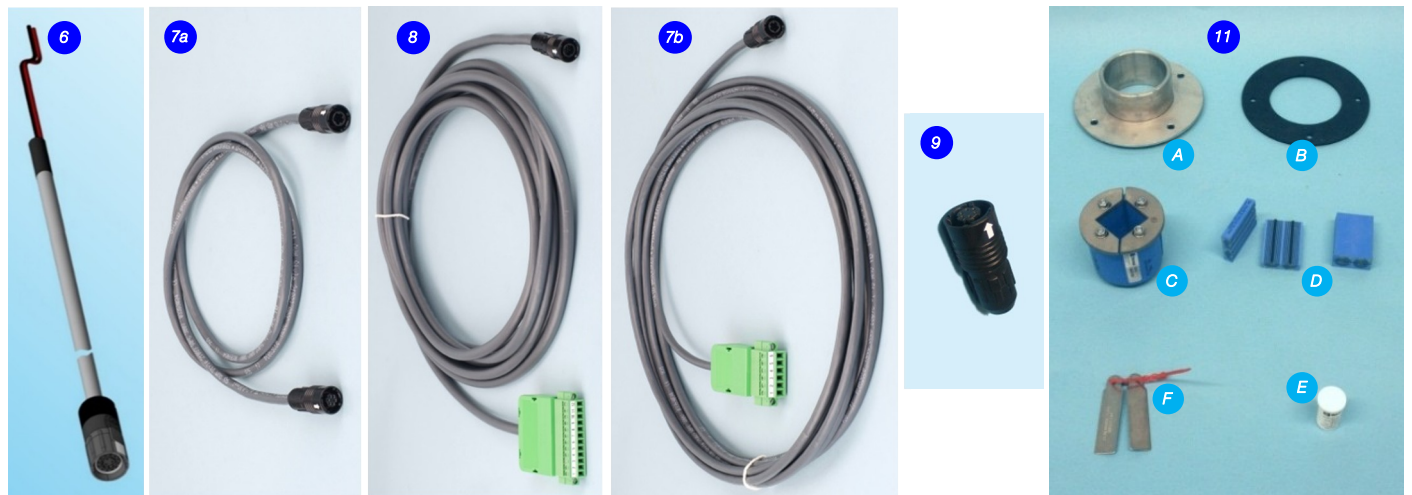


Figure 21: Standard cables

*Levitronix®* is the world-wide leader in magnetically levitated bearingless motor technology. *Levitronix®* was the first company to introduce bearingless motor technology to the Semiconductor, Medical and Life Science markets. The company is ISO 9001 certified. Production and quality control facilities are located in Switzerland. In addition, *Levitronix®* is committed to bring other highly innovative products like the *LEVIFLOW®* flowmeter series to the market.



#### Headquarter and European Contact

Levitronix GmbH  
Technoparkstr. 1  
CH-8005 Zurich  
Switzerland

Phone: +41 44 974 4000  
E-Mail: [salesEurope@levitronix.com](mailto:salesEurope@levitronix.com)

#### US Contact

Levitronix Technologies Inc.  
10 Speen Street, Suite 102  
Framingham, Massachusetts 01701  
USA

Phone: +1 508 861 3800  
E-Mail: [salesUS@levitronix.com](mailto:salesUS@levitronix.com)

#### Japan Contact

Levitronix Japan K.K.  
Wing Eight 5floor, 4-16-4  
Asakusabashi, Taito-ku  
Tokyo, 111-0053 Japan

Phone: +81 3 5823 4193  
E-Mail: [salesJapan@levitronix.com](mailto:salesJapan@levitronix.com)

#### Taiwan Contact

Levitronix Taiwan  
5F, No. 251, Dong Sec. 1,  
Guangming 6th Rd., Chu Pei City,  
Hsin-Chu 302, Taiwan, R.O.C.

Phone: +886 3 657 6209  
E-Mail: [salesAsia@levitronix.com](mailto:salesAsia@levitronix.com)