

LEVIFLOW® Ultrasonic Flowmeters Ultraclean Fluid Handling



LFS Flowmeter Series

LFS-008: 0 – 0.8 l/min

LFS-04: 0 – 4 l/min

LFS-08: 0 – 8 l/min

LFS-20: 0 – 20 l/min

LFS-50: 0 – 50 l/min

LFS-80: 0 – 80 l/min

Ultraclean Non-Invasive Flow Measurement!

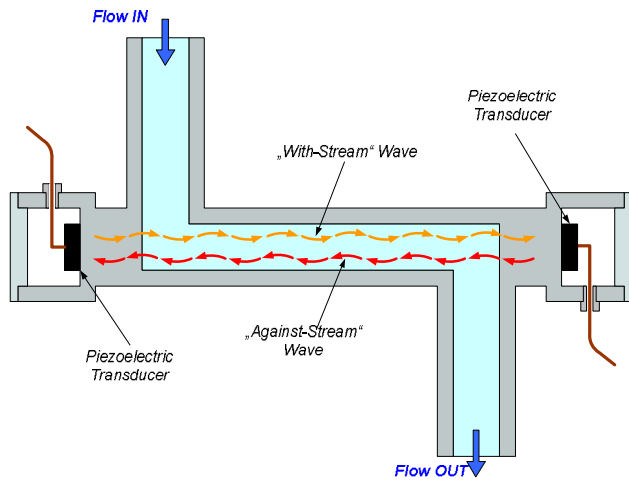

Figure 1: Operating principle ultrasonic flowmeter sensor with Z-shape (same principle with U-shape)

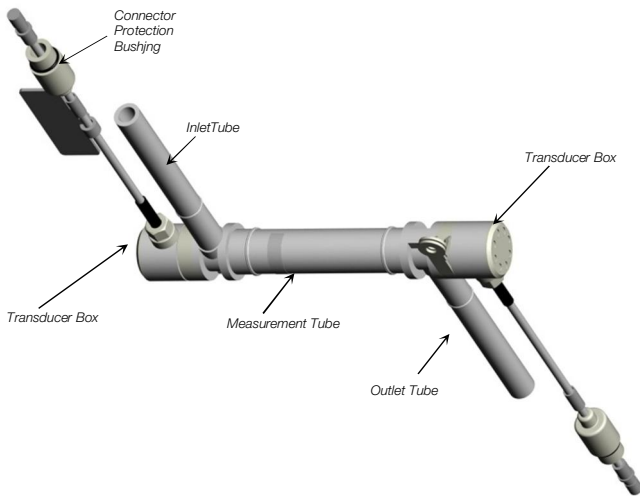

Figure 2: Flow sensor design (example LFS-04 for 4 l/min)

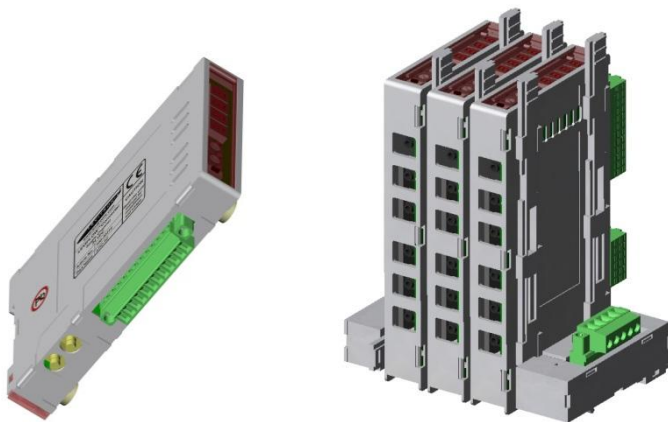

Figure 3: Single channel (left) and multi-channel converter (right)

INTRODUCTION

The *LEVIFLOW*[®] LFS flowmeter series is designed for non-invasive high precision flow measurements of high purity fluids. *Figure 1* illustrates the operating principle. Two piezoelectric transducers, mounted at both ends of the measuring path of the fluid stream, generate and receive an ultrasonic wave. The wave going in direction of the flow (with-stream wave) is accelerated and the wave going against (against-stream wave) the flow direction is slowed down. The two waves are processed by a signal converter. The difference of the transmit time of both waves is proportional to the velocity of the fluid.

The standard configuration of the *LEVIFLOW*[®] flowmeters consists of a flow sensor (see *Figure 2*) and a converter (see *Figure 3*) with a digital signal processor (DSP) for processing the sensor signals. Five flow sensor sizes are available to measure flows from the ml/min range up to 80 l/min. Various signals (analog output, digital input and digital output) are provided and can be configured with a PC software. A two wire RS485 bus allows arrays of multiple flow-meters. In addition, the sensor value is shown on a 4-digit display.

For high volume applications multi-channel converters (see *Figure 8* or *Figure 9*) are available, which processes 6 sensors with one single converter. The sensor signals are available over a RS485 two wire bus or a PLC interface (see *Figure 9*), hence reducing significantly cabling, space and costs. The multi-channel converters can be stacked to a multiple array (see *Figure 3*).

SYSTEM BENEFITS

- No contamination due to non-invasive measurement
- High accuracy (1% of reading) and repeatability ($\leq 0.5\%$)
- No moving parts -> no particle generation
- Improved bubble robustness due to DSP technology
- High precision flow control together with *Levitronix*[®] MagLev Pumps
- Easy configurable flow sensor parameters (PC software)

APPLICATIONS

- High purity liquid processes in Semiconductor manufacturing
- CMP slurry flow control
- Sterile non-invasive flow measurement in Pharmaceutical manufacturing
- Flow control in combination with *Levitronix*[®] MagLev pump systems

FLOW CONTROL IN COMBINATION WITH LEVITRONIX MAGLEV PUMP SYSTEMS

Without the need of additional controller hardware, precise ultrapure flow control systems can be realized with *LEVIFLOW*[®] flowmeters in combination with *Levitronix*[®] MagLev pumps (see *Figure 4*). The flow control firmware which comes with the *Levitronix*[®] pump systems *BPS-1*, *BPS-3*, *BPS-4*, *BPS-200*, *BPS-600* and *BPS-2000* electronically regulates the pump speed in order to achieve the desired flow rate. With the current product family, flow control ranges from 30 ml/min up to 80 l/min can be realized.

To facilitate matters, *Levitronix*[®] provides either turnkey solutions for closed-loop flow control or helps to design your own flow control system. Experience has been gained with fluids such as CMP slurries, surface-conditioning chemicals, plating solutions, ultrapure water and solvents. A block-diagram for a typical point of use flow control system with an additional pre-pressure regulator is shown in *Figure 5*.

The versatility of *Levitronix*[®] flow control systems goes far beyond the capabilities of simple flow controllers. In addition to the flow control function, the *Levitronix*[®] control firmware comes with several condition monitoring features to monitor the integrity of the fluid circuit. *Levitronix*[®] flow control systems can generate alarms for preventive filter exchange, no-flow conditions or line clogging. Dynamic Condition Trending (DCT) enables failure prediction and scheduling of preventive maintenance (*Figure 6*).

SYSTEM BENEFITS

- Precise flow control from 30 ml/min up to 80 l/min (lower flows on request)
- Wide turn-down ratio compared to simple flow controllers
- Alarming capability for flow, speed, current, temperature, line clogging (elimination of catastrophic product loss by elimination of no-flow condition during processing), bubble detection
- Dynamic Condition Trending (DCT) capability (enables failure prediction and scheduling of preventive maintenance or filter exchange)
- Continuous, smooth process flow (stable flow, even with pressure fluctuations on the delivery line!)
- Fully independent from pressure on chemical delivery line (no minimum pressure required!)
- CMP-slurry savings based on reduced slurry flow rate

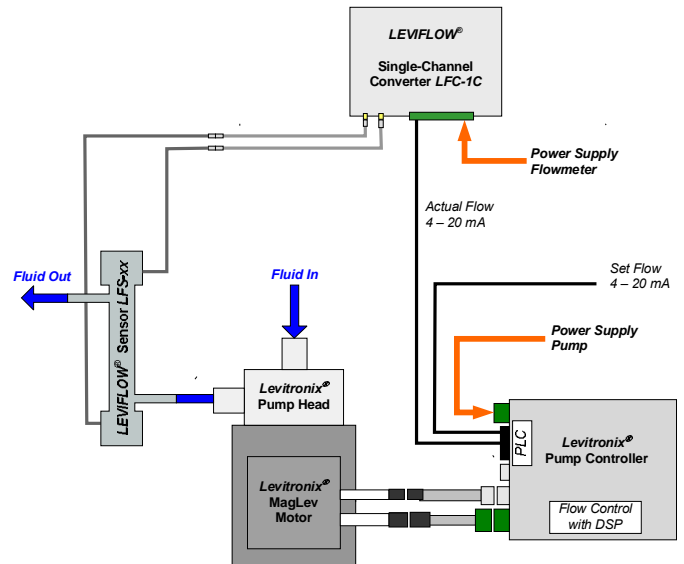

Figure 4: Basic configuration for flow control with Levitronix[®] pump systems

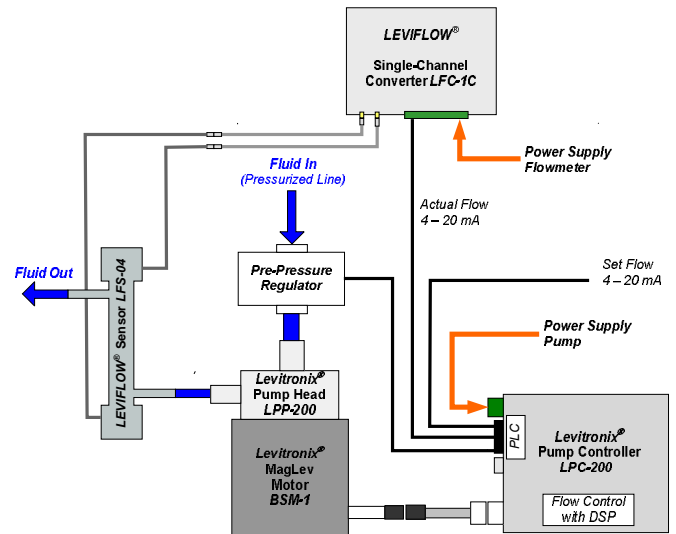

Figure 5: Point-of-use flow control flowmeter LFS_04 and pump system BPS-200

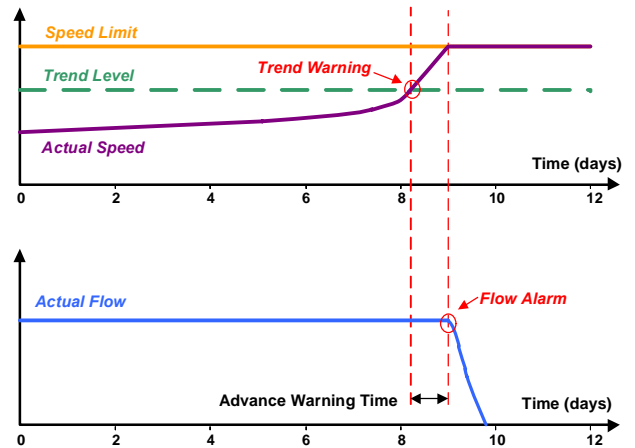

Figure 6: Dynamic Condition Trending (DCT)

SYSTEM CONFIGURATIONS

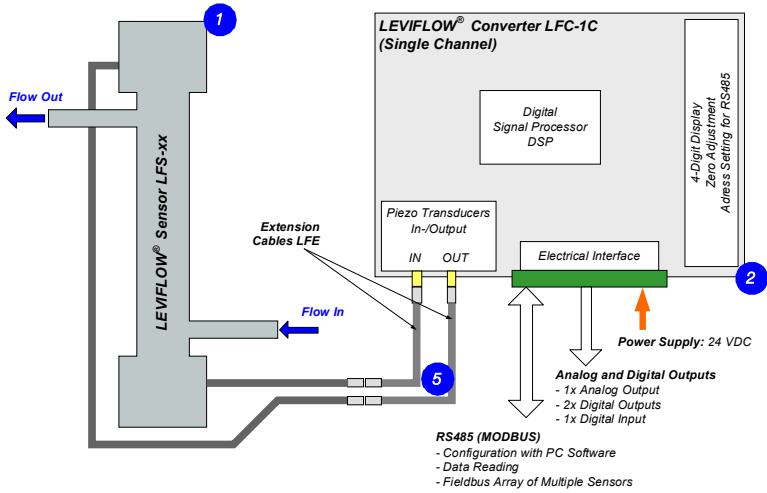

Figure 7: Standard system configuration of LFC-1C and LFC-1C-F4 (needed for LFS-008)

Analog Outputs (1x)	
Specification	Standard Configuration
4 - 20 mA (0 - 20 mA configurable) Load resistance < 600 Ohm	Flow reading 4-20 mA. Standard full scale flow range of each sensor model.
Digital Outputs (2x)	
Specification	Standard Configuration
Maximum rating: 30 VDC, 20 mA (open collector)	Digital Output 1: Parameter: Flow Alarm High Setting: 105% of full scale Digital Output 2: Parameter: Flow Alarm Low Setting: -5% of full scale Normally opened
Digital Inputs (2x)	
Specification	Standard Configuration
No-voltage contact or transistor open collector.	Zero adjustment.

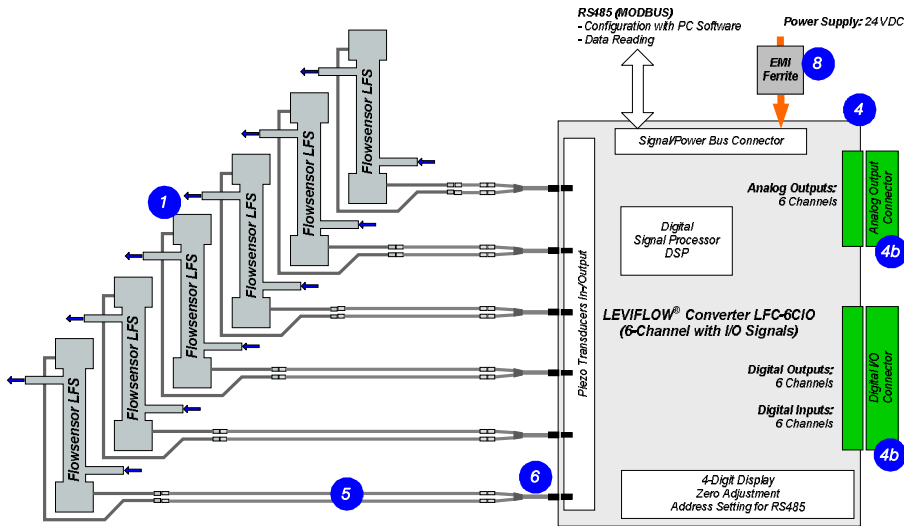

Figure 8: Standard system configuration of LFC-6CIO (with RS485 bus and PLC interface)

Analog Outputs (6 Channels)	
Specification	Standard Configuration
4 - 20 mA Load resistance < 600 Ohm	Flow reading 4-20 mA. Standard full scale flow range of each sensor model. (0 - 20 mA configurable)
Digital Outputs (6 Channels)	
Specification	Standard Configuration
Maximum rating: 30 VDC, 20 mA (open collector)	Parameter: Flow Alarm High Setting: 105% of full scale Normally opened
Digital Inputs (6 Channels)	
Specification	Standard Configuration
No-voltage contact or transistor open collector.	Zero adjustment.

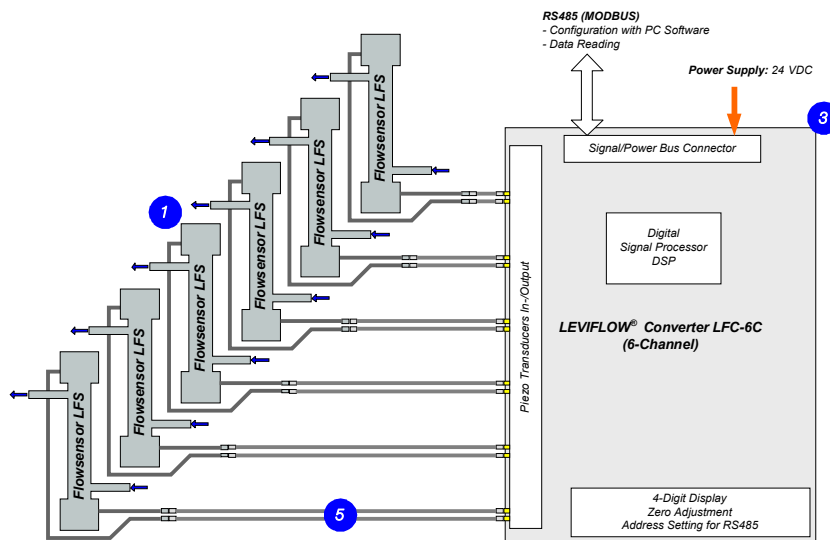

Figure 9: Standard system configuration of LFC-6C (with RS485 bus)

FLOW SENSOR SPECIFICATIONS

Sensor Type		LFS-008	LFS-04(H)	LFS-08(H)	LFS-20(H)	LFS-50(H)	LFS-80(H)
Characteristics							
Flow Range [lpm]		0 – 0.8	0 – 4	0 – 8	0 – 20	0 – 50	0 – 80
Fitting Tube Size (OD)		1/4"	1/4" or 3/8"	3/8"	1/2"	3/4"	1"
Measurement Path ID in [mm]		2.5	4	6	10	15	20
Accuracy	Flow Range [lpm]	0 – 0.035	0 – 0.8	0 – 1.7	0 – 4.7	0 – 10.6	0 – 18.8
Flow Velocity < 1 m/s	Accuracy [lpm]	see Figure 11	± 0.008	± 0 – 0.017	± 0.047	± 0.106	± 0.188
	Repeatability [lpm]	see Figure 11	< 0.004	< 0.009	< 0.024	< 0.053	< 0.094
Accuracy	Flow Range [lpm]	0.035 – 0.8	0.8 – 4	1.7 – 8	4.7 – 20	10.6 – 50	18.8 – 80
Flow Velocity > 1 m/s	Accuracy of Reading	± 1%	± 1%	± 1%	± 1%	± 1%	± 1%
	Repeatability of Read.	< 0.5%	< 0.5%	< 0.5%	± 0.5%	± 0.5%	± 0.5%
Wetted Surface Area [cm ²]		38.3	59.0 (for 3/8")	61.7	87.5	155.9	233.1
Weight [g]		97	97	95	115	150	180
Pressure Drop Coefficient C $\Delta P = C \times Q^2$, Q = Flow [lpm], ΔP = Press. Drop [kPa]		16.8	1.80 for 3/8" 5.41 for 1/4"	0.88	0.06	0.01	0.003
Fluid Temperature		Normal range: 10 – 90 °C (50 – 194 °F)		For LFS-xxH (high-temp version): 10 - 180 °C (50 - 356 °F)			
Ambient Temperature		0 – 60 °C (32 - 140 °F)					
Maximum Fluid Pressure		0 – 0.5 MPa (0 – 5 bar, 0 – 72.5 psi)					
Kinematic Viscosity		0.8 – 40 mm ² /s (0.8 – 40 cSt)					
Sound Speed		1000 – 2200 m/s					
Wet Materials		PFA					
Sensor Enclosure Classification		IP-65					
Cable Jacket Material		FEP (PVC on request and at minimum order quantities)					
Standard Cable Length		0.5m with extension cables for length variation (other length on request and at minimum order quantities)					
Electrical Connectors		SMB with protective PVDF cover (male with O-Ring, IP-65 protection)					

Figure 10: Specifications of sensors (All data based on water at 20 °C)

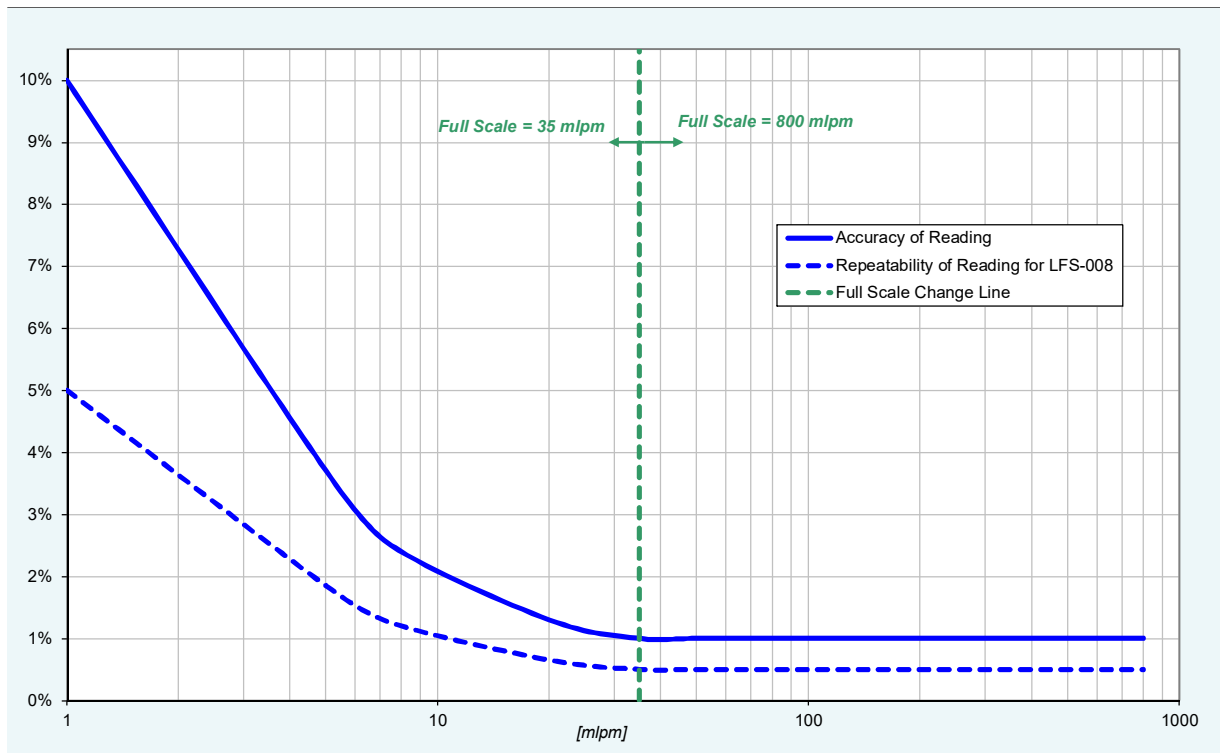

Figure 11: Repeatability and accuracy specification for LFS-008 sensor

CONVERTER SPECIFICATIONS

Characteristics	Single Channel Converter Types LFC-1C and LFC-1C-F4
Power Supply / Current / Inrush (Start) Current	24 VDC \pm 10% / 150 mA / Peak 1.8 A within 100 μ s
Ambient Temp / Humidity Range	0 – 50 °C (32 – 122 °F) / 30 - 85% R.H. (no condensation)
Enclosure Classification and Material	IP-20 (indoor use), ABS
Interfaces	<ul style="list-style-type: none"> - RS485 -> MODBUS protocol -> max. array of 99 channels - 1x Analog Output: 4 – 20mA (0 – 20mA configurable) - 2x Digital Outputs: Flow Alarm, Measurement Error, Volume Counter Pulse, Volume Counter Alarm, Flow as Frequency or Bubble Detection (default: normally open) - 1x Digital Input: Volume Counter Reset or Zero Adjust - 4 Digit display (flow rate, error codes), re-zero button - Address potentiometers for RS485 address setting
Configuration Parameters (Available and configurable with RS485/USB converter and configuration software)	<ul style="list-style-type: none"> - Viscosity - Low Cutoff, - Dampening time (filter) - Full scale setting, - Linearization (15 points) - Alarm Outputs (High and Low Alarm) - Volume Counter and Volume Counter Alarm Settings
Weight / Dimensions / Mounting	130 g / 123 x 75 x 17.5 mm / DIN rail
Duration for Activation of Manual and Digital Zeroing	3 sec
Duration of Zeroing Procedure	LFC-1C: normal 6 sec , maximum 15 sec LFC-1C-F4: normal 26 sec, maximum 60 sec.
Duration of Measurement Ready after Power-On Warm-Up Time for Full Performance Measurements	10 sec. 30 min.

Table 1: Specifications for single-channel converters LFC-1C and LFC-1C-F4

Characteristics	6-Channel Converter Types LFC-6C and LFC-6CIO
Power Supply / Current	LFC-6C : 24 VDC \pm 10% / 150 mA LFC-6CIO : 24 VDC \pm 10% / 270 mA
Power Supply In-Rush (Start) Current	LFC-6C : Peak 1.7 A within 180 μ s LFC-6CIO : Peak 4.9 within 210 μ s
Ambient Temp / Humidity Range	0 – 50 °C (32 – 122 °F) / 30 - 85% R.H. (no condensation)
Enclosure Classification and Material	IP-20 (indoor use), ABS
Interfaces	<ul style="list-style-type: none"> - RS485 -> MODBUS protocol -> max. array of 99 ch. - Stacking of max. 16 converters -> 5 ms DSP process/time per channel - 4 Digit display (flow rate, error codes), re-zero button - Address potentiometers for RS485 address setting <p>For LFC-6CIO only:</p> <ul style="list-style-type: none"> - 6x Analog Outputs: 4 – 20mA (0 – 20mA configurable) - 6x Digital Outputs: Flow Alarm, Measurement Error, Volume Counter Pulse, Volume Counter Alarm, Flow as Frequency or Bubble Detection (default: normally open) - 6x Digital Input: Volume Counter Reset or Zero Adjust
Configuration Parameters (Available and configurable with RS485/USB converter and configuration software)	<ul style="list-style-type: none"> - Viscosity - Low Cutoff - Dampening constant (filter) - Full scale setting - Linearization (15 points) - Alarm Outputs (High and Low Alarm) - Volume Counter and Volume Counter Alarm Settings
Weight / Dimensions / Mounting	LFC-6C: 170 g / 139 x 77 x 17.5 mm / DIN rail LFC-6CIO: 182 g / 139 x 77 x 18.5 mm / DIN rail
Duration for Activation of Manual and Digital Zeroing	3 sec
Duration of Zeroing Procedure	LFC-6C: normal 15 sec, maximum 30 sec. LFC-6CIO: normal 26 sec, maximum 60 sec.
Duration of Measurement Ready after Power-On Warm-Up Time for Full Performance Measurements	10 sec. 30 min.

Table 2: Specifications for multi-channel converters LFC-6C and LFC-6CIO

COMPONENT DIMENSIONS

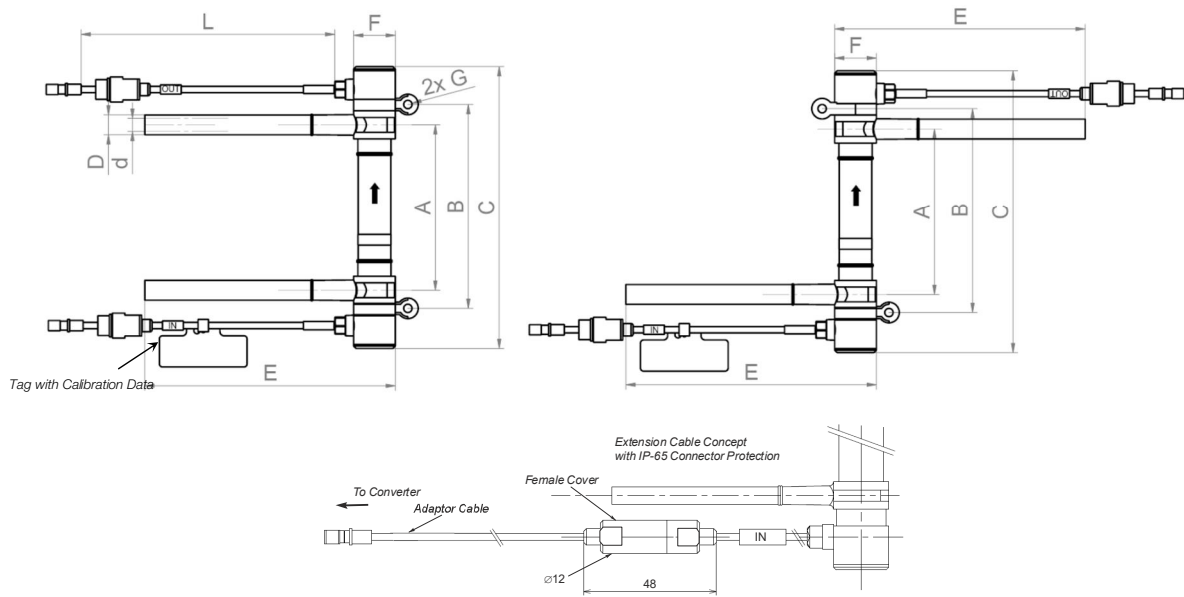

Figure 12: Dimension legend for LFS-04 and LFS-08 sensors (left: U-shape, right: Z-shape)

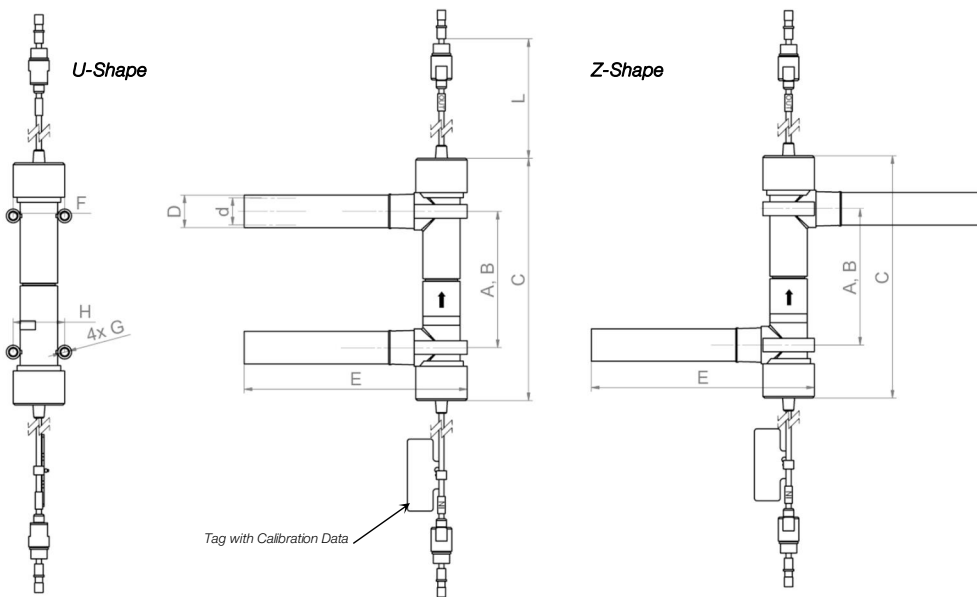

Figure 13: Dimension legend for flowsensors LFS-20, LFS-50 and LFS-80 (left: U-shape, right: Z-shape)

Sensor Type	Tube Size	Dimensions in [mm]									
		A	B	C	D	d	E	F	G	H	L
LFS-008	1/4"	80 ±1	96 ±1	134 ±1	6.35	4.35	120	φ20	φ4	--	500
LFS-04(H)	3/8" 1/4"	80 ±1	98.5 ±1 (99 ±1) 96 ±1	136 ±1 134 ±1	9.53 6.35	6.33 4.35	120	φ20	φ4	--	500
LFS-08(H)	3/8"	80 ±1	98.5 ±1 (100 ±1)	136 ±1 (137 ±1)	9.53	6.33	120	φ20	φ4	--	500
LFS-20(H)	1/2"	80 ±1	80 ±1	136 ±1	12.7	9.5	120 (117.7)	φ30 (φ25.4)	M4 x 31 -> U-shape M4 x 30 -> Z-shape Max. Torque: 0.3 Nm	25	500
LFS-50(H)	3/4"	80 ±1	80 ±1	141.8 ±1 (143.8 ±1)	19	15.8	130 (127.7)	φ30 (φ25.4)	M5 x 31 -> U-shape M5 x 30 -> Z-shape Max. Torque: 0.5 Nm	30	500
LFS-80(H)	1"	80 ±1	80 ±1	148 ±1	25.4	22.2	140 (137.7)	φ30 (φ25.4)	M4 x 34 -> U-shape M4 x 30 -> Z-shape Max. Torque: 0.3 Nm	35	500

Table 3: Sensor dimensions

COMPONENT DIMENSIONS

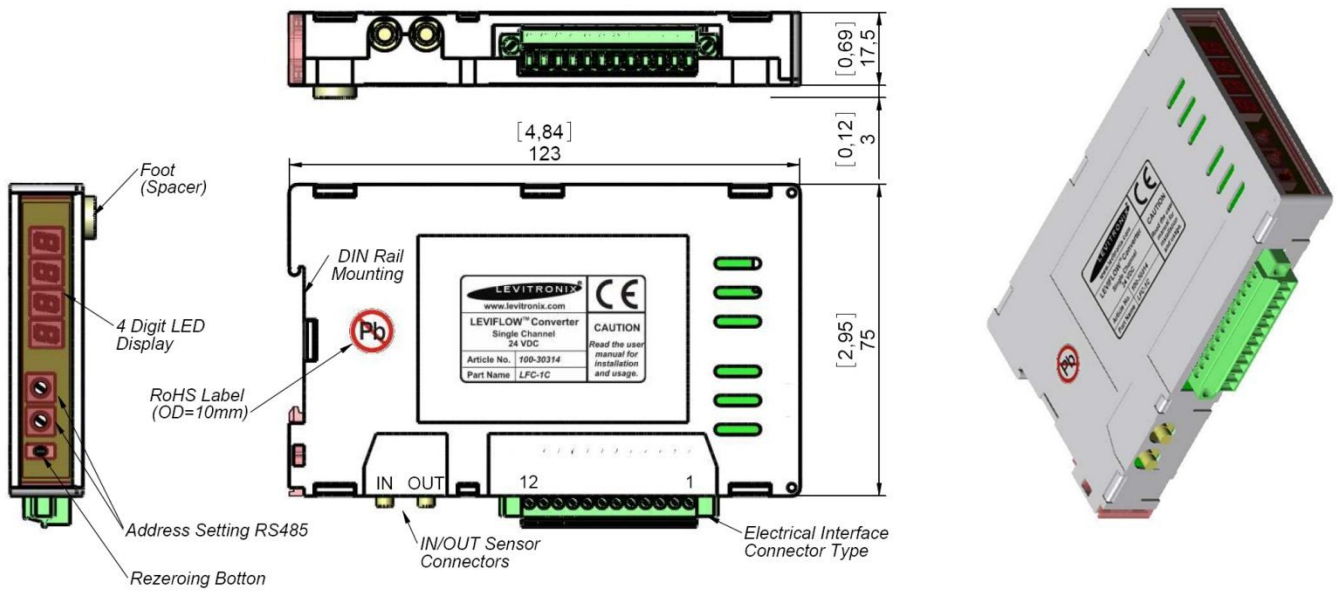

Figure 14: Dimensions and layout of interfaces of single channel converter LFC-1C / LFC-1C-F4

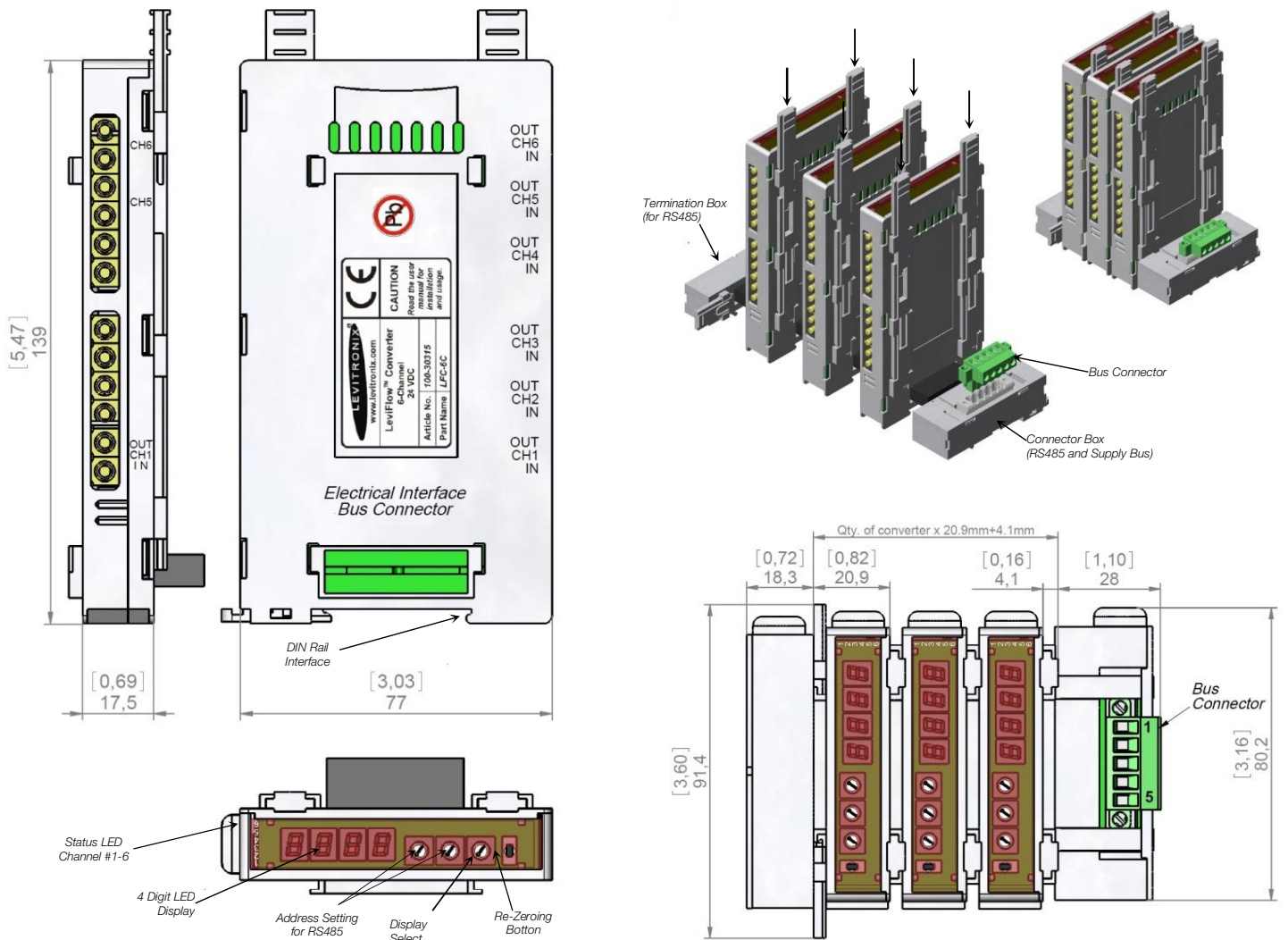

Figure 15: Dimensions, mounting and stacking concept for LFC-6C

COMPONENT DIMENSIONS

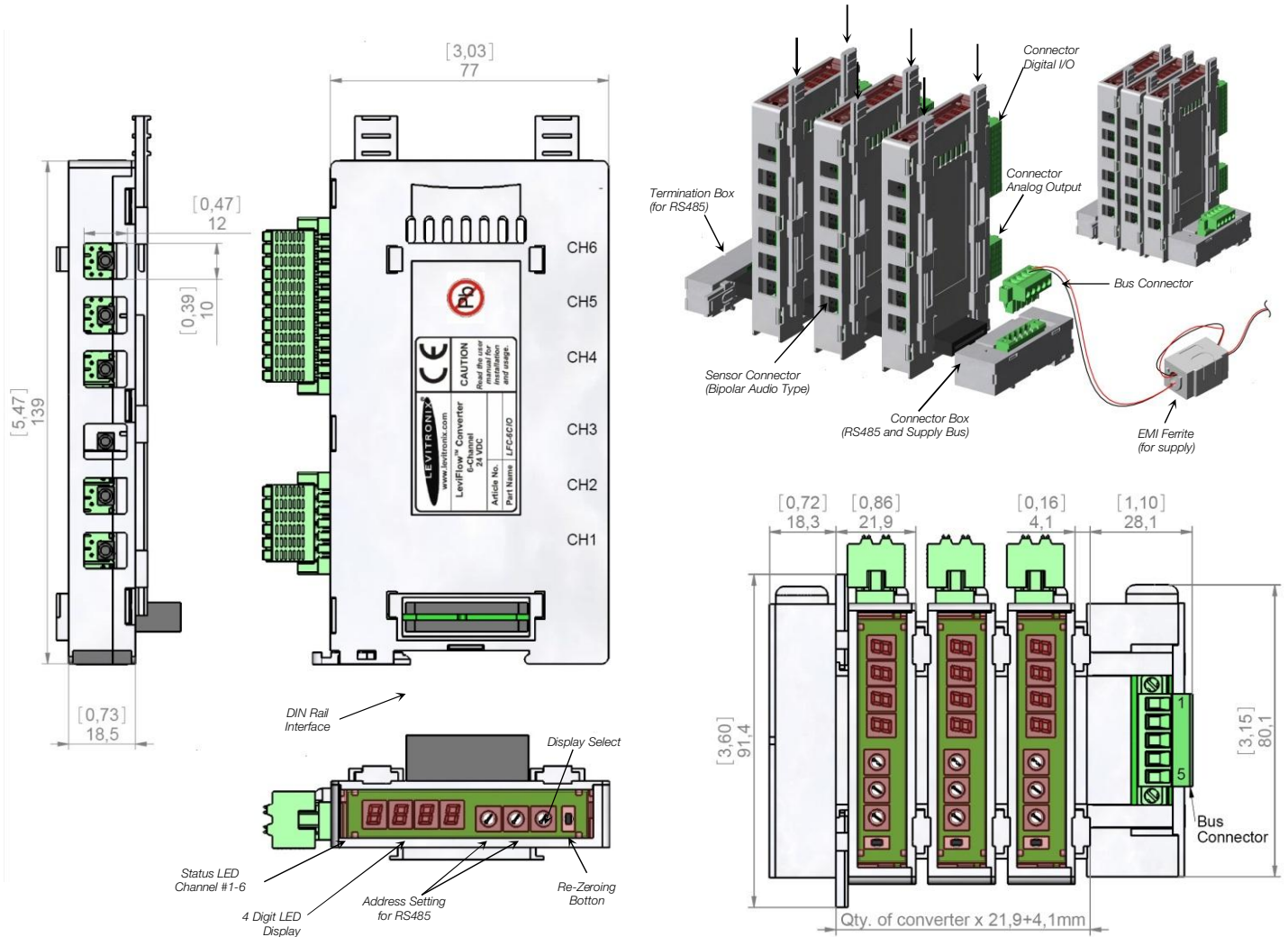

Figure 16: Dimensions, mounting and stacking concept of LFC-6CIO

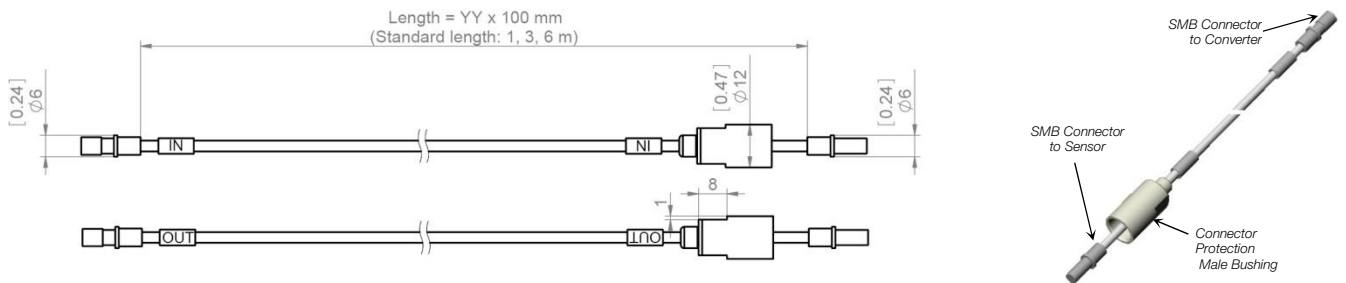

Figure 17: Adaptor cable LFE-A.1 (delivered in pairs for "IN" and "OUT" sensor cable).

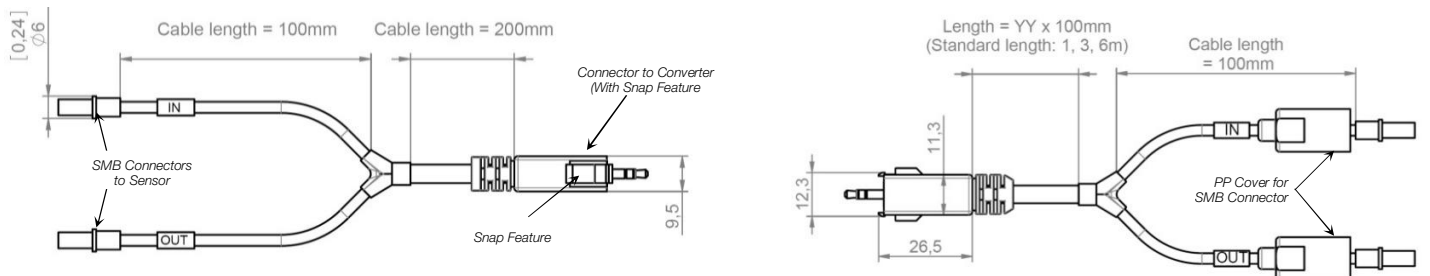

Figure 18: Y-shape adaptor cables LFA-A.1 (left) and LFE-D.1-yy (right) for LFC-6CIO converter

ORDER INFORMATION

Pos.	Part Name	Part #	Shape	Flow	Max. Liquid Temp.	Fitting (Tube)	Cable	Special Feature	Note
1a	LFS-008-Z / LFS-008-U	100-30323 / 100-30324	Z / U	0 – 0.8 lpm	90 °C	1/4"	FEP 0.5 m	PVDF male connector cover	Sensor specific parameter for converter calibration are delivered on a tag attached to the flowsensor.
1b	LFS-04-Z-T025 / LFS-04-U-T025	100-30321 / 100-30322	Z / U	0 – 4 lpm	90 °C	1/4"			
1c	LFS-04-Z / LFS-04-U	100-30304 / 100-30305	Z / U	0 – 4 lpm	90 °C	3/8"			
1d	LFS-04H-Z / LFS-04H-U	100-30330 / 100-30331			180 °C				
1e	LFS-08-Z / LFS-08-U	100-30306 / 100-30307	Z / U	0 – 8 lpm	90 °C	3/8"			
1f	LFS-08H-Z / LFS-08H-U	100-30332 / 100-30333			180 °C				
1g	LFS-20-Z / LFS-20-U	100-30308 / 100-30309	Z / U	0 – 20 lpm	90 °C	1/2"			
1h	LFS-20H-Z / LFS-20H-U	100-30372 / 100-30373			180 °C				
1i	LFS-50-Z / LFS-50-U	100-30310 / 100-30311	Z / U	0 – 50 lpm	90 °C	3/4"			
1j	LFS-50H-Z / LFS-50H-U	100-30340 / 100-30341			180 °C				
1k	LFS-80-Z / LFS-80-U	100-30312 / 100-30313	Z / U	0 – 80 lpm	90 °C	1"			
1l	LFS-80H-Z / LFS-80H-U	100-30342 / 100-30343			180 °C				

Table 4: Standard flow sensor models

Pos.	Article Name	Part #	Description	Interfaces
2a (with 2c)	LFC-1C	100-30314	Single Channel Converter (Interface connector 2c included)	Analog Output (4 – 20 mA), 2x Digital Output, 1x Digital Input, RS485 (MODBUS) Note: LFC-1C-F4 works with LFS-008 only.
2b (with 2c)	LFC-1C-F4	100-30325		
3	LFC-6C	100-30315	6-Channel Converter	- RS485 (MODBUS) - Order Bus Conn. (7a) and Terminat. Box (7b) as separate article (see Table 6) Note: Does not work with LFS-008 sensor.
4 (with 4a and 4b)	LFC-6CIO	100-30337	6-Channel Converter with I/O Interfaces (Digital I/O connector 4a and analog output connector 4b included)	- RS485 (MODBUS) protocol - 6 analog outputs (4 – 20 mA), 6 digital inputs, 6 digital outputs - Order Bus Conn. (7a) and Terminat. Box (7b) as separate article (see Table 6) - EMI ferrite (8) to be ordered as separate article (see Table 6)

Table 5: Standard converters

Pos.	Article Name	Part #	Description	Special Feature/Note
5a	LFE-A.1-10	190-10162	Cable length: 1 m, PVC	- PP female connector cover for IP-65 chemical protection - Flame retardant PVC white (UL VW-1 corresponds to EN-60332-1-2)
	LFE-A.1-30	190-10163	Cable length: 3 m, PVC	
	LFE-A.1-60	190-10164	Cable length: 6 m, PVC	
5b	LFE-A.2-10	190-10165	Cable length 1 m, FEP	PP female connector cover for IP-65 chemical protection
	LFE-A.2-30	190-10166	Cable length 3 m, FEP	
	LFE-A.2-60	190-10167	Cable length 6 m, FEP	
6a	LFE-D.1-10	190-10296	Y cable, 1 m, PVC, connector cover	For LFC-6CIO, with SMB connector cover for IP65 protection
	LFE-D.1-30	190-10297	Y cable, 3 m, PVC, connector cover	
	LFE-D.1-60	190-10298	Y cable, 6 m, PVC, connector cover	
6b	LFA-A.1	190-10268	Y adaptor cable, PVC	For LFC-6CIO
7a	Connector Box for LFC-6C	100-30316	COMBICON connector	For wiring RS485 and supply of stacks of LFC-6C and LFC-6CIO converters.
7b	Termination Box for LFC-6C	100-30317	--	For termination of RS485 bus of LFC-6C and LFC-6CIO.
8	LeviFlow Splitting Ferrite	100-30353	EMI filtering of DC supply	For LFC-6CIO supply needed.
9	USB to RS485 Adaptor-TR Isolated YN-485I-TR	100-30392	Structure/Design	USB connector (9a) with termination resistor and cable with connector pair (9b and 9c) for external RS485 wire connection. Magnetically isolated. Cable length is 2m.
			Purpose	Communication over fieldbus of Converter with PC

Table 6: Accessories

Pos.	Part Name	Part #	Flow Range	Fitting (Tube)	Max. Liquid Temp.	Sensor Cable	Note
9a	LFS-008-Z + LFC-1C-F4	100-90625	0 – 0.8 lpm	1/4"	90 °C	FEP 0.5 m	Converter is delivered with sensor specific parameters already stored.
	LFS-008-U + LFC-1C-F4	100-90626					
9b	LFS-04-Z-T025+LFC-1C	100-90627	0 – 4 lpm	1/4"	90 °C		
	LFS-04-U-T025+LFC-1C	100-90628					
9c	LFS-04-Z+LFC-1C	100-90604	0 – 4 lpm	3/8"	90 °C		
	LFS-04-U+LFC-1C	100-90605			90 °C		
	LFS-04H-Z+LFC-1C	100-90630			180 °C		
	LFS-04H-U+LFC-1C	100-90631			180 °C		
9d	LFS-08-Z+LFC-1C	100-90606	0 – 8 lpm	3/8"	90 °C		
	LFS-08-U+LFC-1C	100-90607			90 °C		
	LFS-08H-Z+LFC-1C	100-90813			180 °C		
	LFS-08H-U+LFC-1C	100-90812			180 °C		
9e	LFS-20-Z+LFC-1C	100-90608	0 – 20 lpm	1/2"	90 °C		
	LFS-20-U+LFC-1C	100-90609			90 °C		
	LFS-20H-Z+LFC-1C	100-90835			180 °C		
	LFS-20H-U+LFC-1C	100-90836			180 °C		
9f	LFS-50-Z+LFC-1C	100-90621	0 – 50 lpm	3/4"	90 °C		
	LFS-50-U+LFC-1C	100-90622			90 °C		
	LFS-50H-Z+LFC-1C	100-90802			180 °C		
	LFS-50H-U+LFC-1C	100-90714			180 °C		
9g	LFS-80-Z+LFC-1C	100-90623	0 – 80 lpm	1"	90 °C		
	LFS-80-U+LFC-1C	100-90624			90 °C		
	LFS-80H-Z+LFC-1C	100-90715			180 °C		
	LFS-80H-U+LFC-1C	100-90716			180 °C		

Table 7: Flowmeter sets – flow sensor with single channel converter LFC-1C/LFC-1C-F4

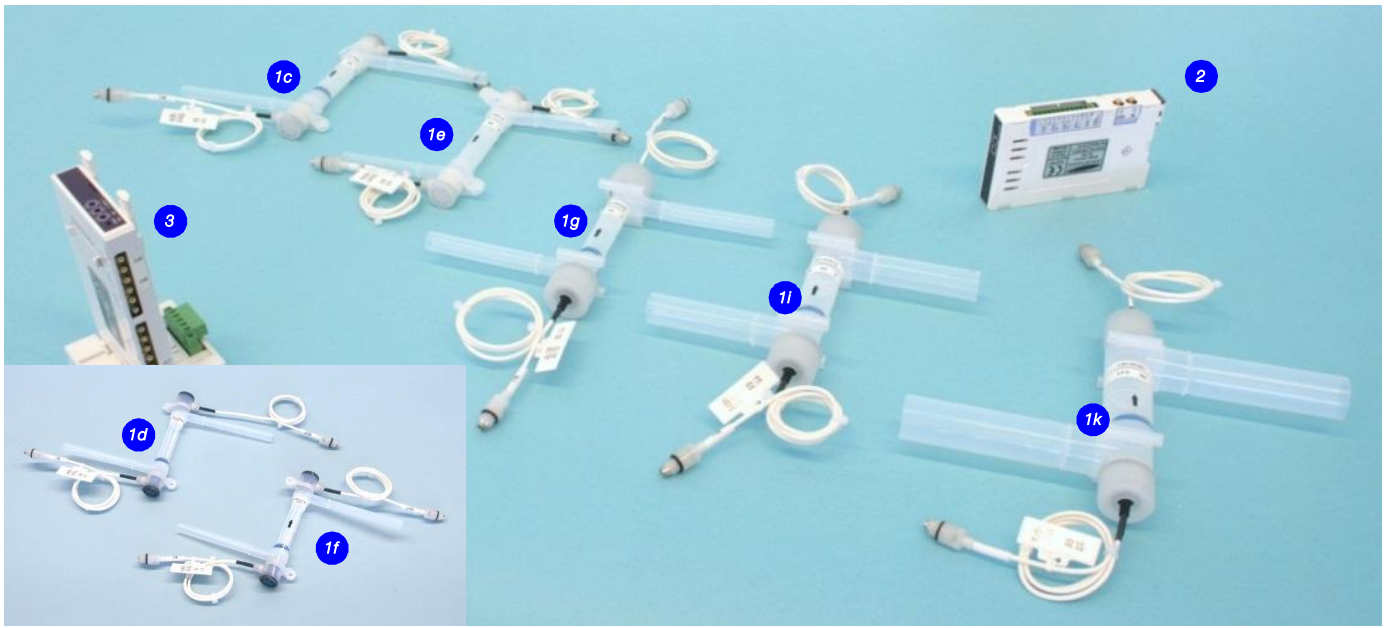

Figure 19: Standard LEVIFLOW® LFS flow sensors

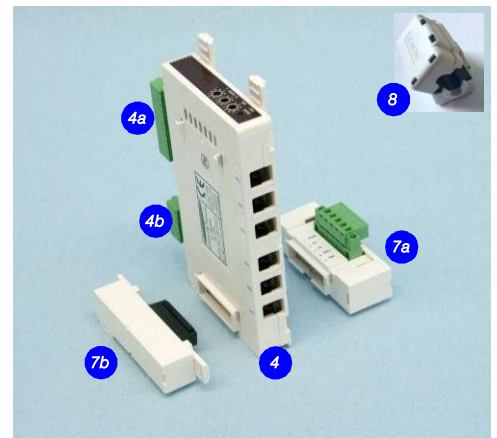
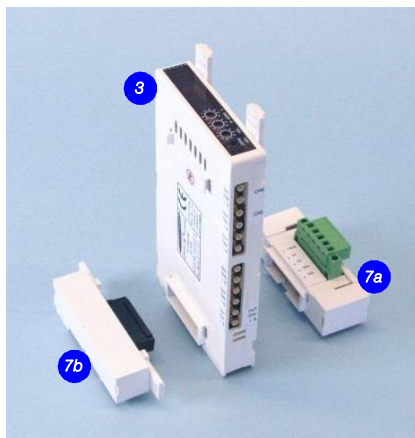
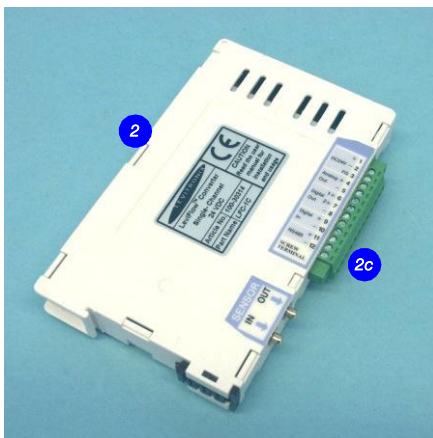

Figure 20: Standard LEVIFLOW® LFC converters



Figure 21: LEVIFLOW® accessories

Levitronix® is the world-wide leader in magnetically levitated bearingless motor technology. Levitronix® was the first company to introduce bearingless motor technology to the Semiconductor, Medical and Lifescience markets. The company is ISO 9001 certified. Production and quality control facilities are located in Switzerland. In addition, Levitronix® is committed to bring other highly innovative products like the LEVIFLOW® flowmeter series to the market.



Headquarter and European Contact

Levitronix GmbH
Technoparkstr. 1
CH-8005 Zurich
Switzerland

Phone: +41 44 445 19 13
Fax: +41 44 445 19 14
E-Mail: salesEurope@levitronix.com

US Contact

Levitronix Technologies LLC
20 Speen Street, Suite 102
Framingham, Massachusetts 01701
USA

Phone: +1 508 861 3800
Fax: +1 508 861 3837
E-Mail: salesUS@levitronix.com

Japan Contact

Levitronix Japan K.K.
Wing Eight 5floor, 4-16-4
Asakusabashi, Taito-ku
Tokyo, 111-0053 Japan

Phone: +81 3 5823 4193
Fax: +81 3 5823 4195
E-Mail: salesJapan@levitronix.com

Taiwan Contact

Levitronix Taiwan
5F, No. 251, Dong Sec. 1, Guangming
6th Rd., Chu Pei City,
Hsin-Chu 302, Taiwan, R.O.C.

Phone: +886 3 657 6209
Fax: +886 988 321472
E-Mail: salesAsia@levitronix.com