

Ultrapure Fluid Handling Integrated Flow Controller Series



BPS-iF100

Pump Pressure / Flow: 2 bar / 20 l/min

Flow Control Ranges:

4 l/min

8 l/min

20 l/min

High Precision. No Bearings. No Contamination!

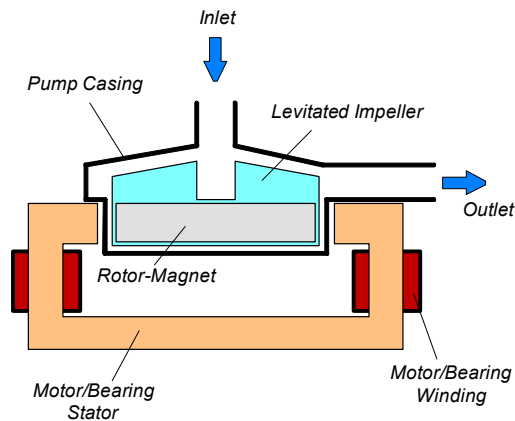

Figure 1: Schematic of the main elements of the MagLev centrifugal pump

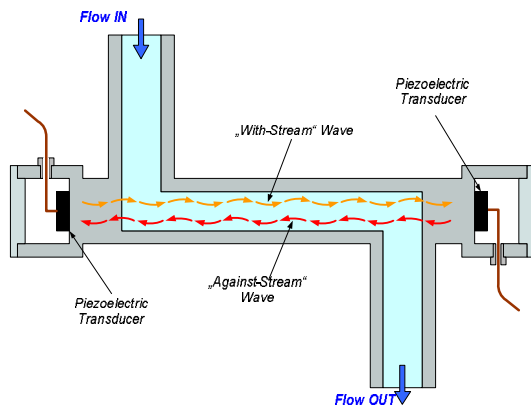

Figure 2: Operating principle ultrasonic flowmeter sensor with Z-shape (same principle with U-shape)

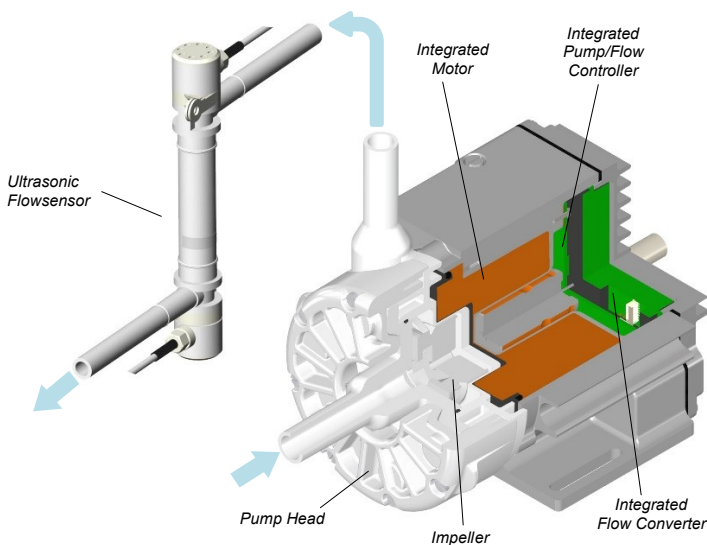

Figure 3: Integrated MagLev flow control system with ultrasonic flow sensor.

INTRODUCTION

With the *BPS-iF100* flow control system *Levitronix*[®] combines its unique magnetic levitation pump technology with its ultrasonic flow measurement technology. The result is a highly integrated precise flow controller with an integrated pressure source.

The centrifugal pump, as a pressure source, has no bearings to wear out or seals to break down and fail. The pump impeller is suspended, contact-free, inside a casing and is driven by the magnetic field of the motor (*Figure 1*).

The flow is measured with the proven *LEVIFLOW*[®] ultrasonic sensor technology not invading into the fluid path (*Figure 2*).

The pump head and flow sensor is fabricated from chemical-resistant high purity fluorocarbon resins. The pump controller, motor and flow converter are integrated into the driver housing (see *Figure 3*). This reduces cabling and setup effort significantly. Fluid flow rate is precisely controlled by electronically regulating the impeller speed without pulsation.

SYSTEM BENEFITS

- High precision, dynamics and high turndown ratio.
- No dependency on external pressure source.
- Extremely low particle generation due to the absence of mechanically contacting parts.
- Increased equipment uptime with lower maintenance costs by eliminating valves, bearings, rotating seals and costly rebuilds.
- Very low integration costs as no external controller is needed for flow control.
- Reduced risk of contamination due to the self-contained design with magnetic bearings and ultrasonic technology.
- Very gentle to sensitive fluids due to low-shear design.
- No narrow gaps and fissures where particles or microorganisms could be entrapped.
- Smooth, continuous flow without pressure pulsation.
- Proven pump and ultrasonic flow measurement technology

APPLICATIONS

- Semiconductor wet processing (Cleaning, CMP etc.).
- Flip chip and advanced packaging.
- Solar cell production.
- Flat panel display manufacturing.
- Hard-disk fabrication.
- Printer ink handling.
- Pharmaceutical production.
- Plating.
- Circulation in flow batteries.

BASIC SYSTEM CONFIGURATION

Figure 7 illustrates the interfacing of the integrated flow control system. Various PLC signals allow a simple setup with precisely setting the speed via an analog input. Various digital inputs and outputs allow controlling and monitoring of the system.

A RS485 interface allows communication with a PC in connection with the Levitronix® Service Software. Hence parameterization, firmware updates and failure analysis are possible. Furthermore, the user hence is able to optimize the system to various specific situations.

Stand-alone operation is possible with a user panel, which is attached to the Fieldbus interface.

The RS485 can also be used as a fieldbus to implement more intelligent concepts of flow control. The fieldbus also allows control of multiple systems.

FLOWCONTROL CONCEPT AND MAIN BENEFITS

Figure 5 illustrates the flow control concept with the BPS-iF100. Flow control, pressure generation and flow measurement is done with one unit. This allows realization of sophisticated flow control algorithms and optimizations to various situations.

There is a linear relationship between flow and speed (see Figure 5). The speed is precisely controlled with a high resolution over a wide speed range. This allows a flow control with high resolution and high turndown ratio compared to non-linear flow control with valve type flow control concepts. Additionally, the highly dynamic speed controller allows fast flow step responses.

As the speed is monitored and as the pressure cannot increase uncontrolled at a given speed, there is no need to protect the hydraulic circuit against over-pressure situations as for example for roller pumps in tube clogging situations.

CAPABILITIES OF FLOWCONTROL SYSTEM

The versatility of the BPS-iF100 flow control systems goes far beyond the capabilities of simple flow controllers. In addition to the flow control function, the Levitronix® control firmware comes with several condition monitoring features to monitor the integrity of the fluid circuit. Levitronix® flow control systems can generate alarms for preventive filter exchange, no-flow conditions or line clogging. Dynamic Condition Trending (DCT) enables failure prediction and scheduling of preventive maintenance (Figure 6).

ATEX / IECEx SYSTEM CONFIGURATION

An ATEX / IECEx certified driver (OEM model only) together with the pump head allows installation within an Ex Zone 2 area (see Figure 8). An Ex conform solution is needed for the motor cables to leave the Ex area. One option is an ATEX certified cable sealing system as listed in Table 5 (see Pos. 8).

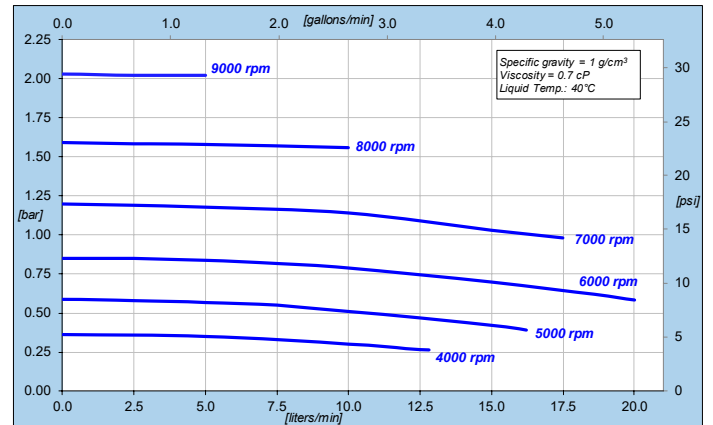

Figure 4: Pressure/flow curves for aqueous liquids (similar to water)

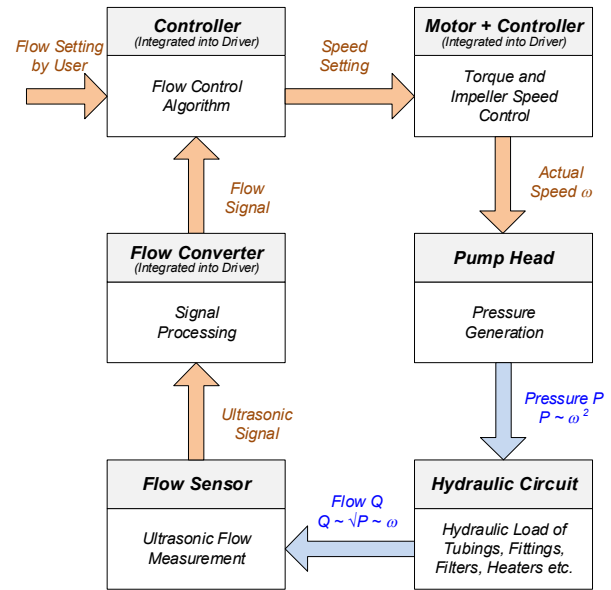

Figure 5: Simplified block schematics of flow control with BPS-iF100

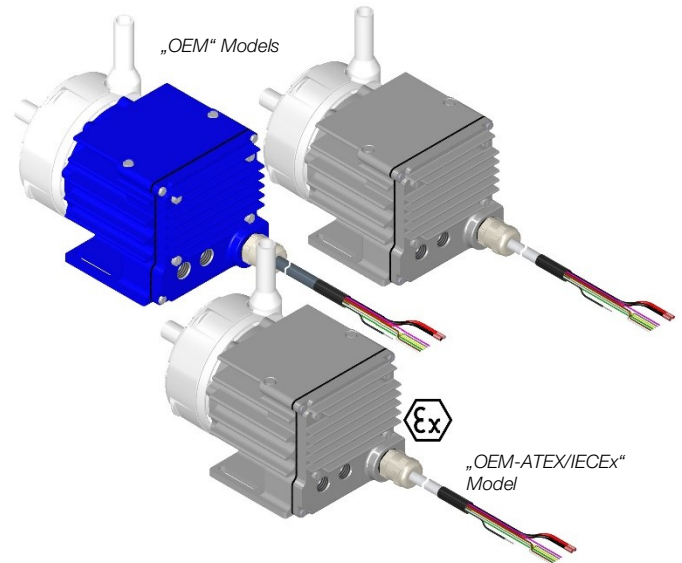

Figure 6: Flow control system models

System Configurations

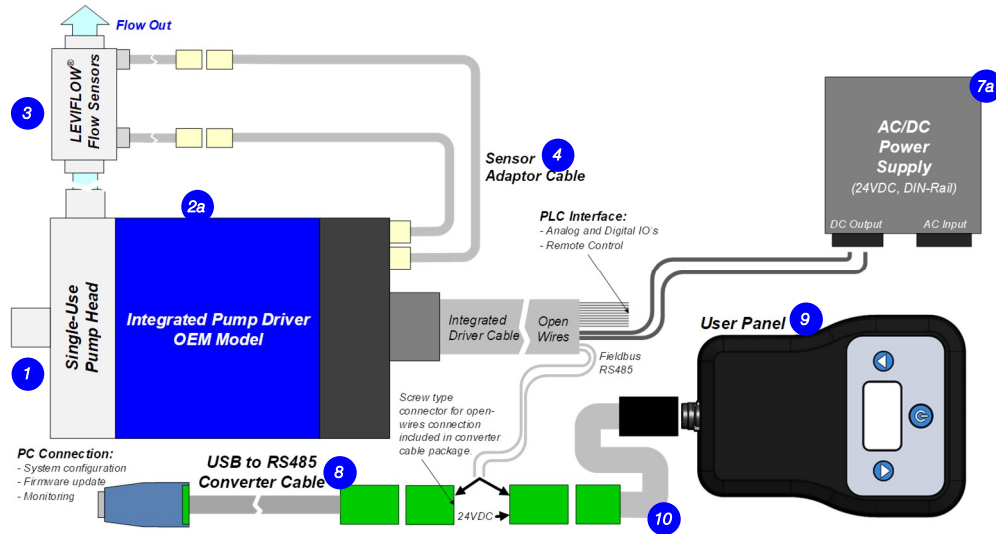

Figure 7: Standard "OEM" system configuration (See section "Order Information" for details to numbered components and other options)

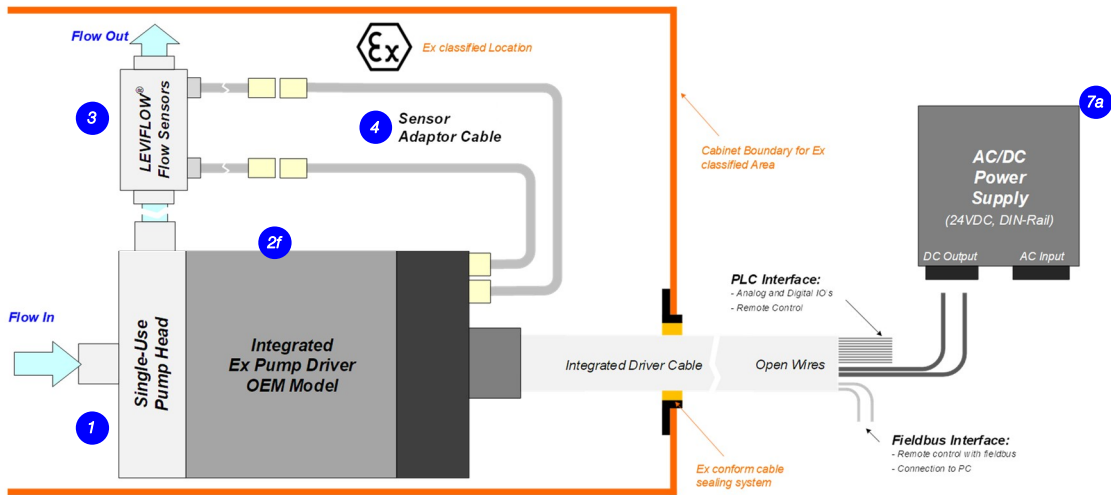
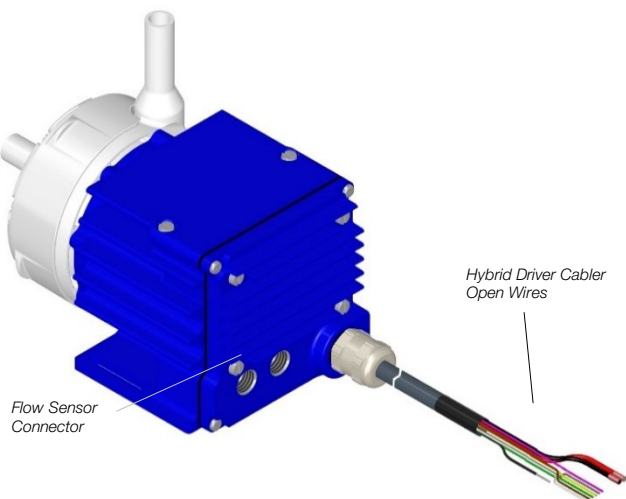

Figure 8: Standard ATEX/IECEx "OEM" system configuration (See section "Order Information" for details to numbered components and other options)



Wire Name	Description	Standard Designation	Hardware Specification
P+	+ 24 VDC	Supply	Voltage: 24 VDC P- to be connected to earth
P-	Power Input Ground / Earth		
Ain1	Analog Input 1 (Current Input)	Reference Value (Set Flow)	Analog current input: 4 – 20 mA (450 Ohm shunt input, no galvanic isolation)
Ain2	Analog Input 2 (Voltage Input)	Free Configurable	Analog voltage input: 0 – 10V (7.9 kOhm, no galvanic isolation)
Ain_GND	Analog Input, Ground	--	Reference for Ain1 and Ain2
Din1	Digital Input 1	Enable (Reset)	Galvanic separation with optocoupler
Din2	Digital Input 2	Zero Adjust	2.2 kΩ input resistance, 5-24V for active input
Din_COM	Common Digital Input	--	--
Aout1	Analog Output	Actual Flow	0 – 10V (no galvanic isolation) AGND is reference
Dout1	Digital Output 1	Status Pump	Open drain, max. 24V, 100mA
Dout2	Digital Output 2	Status Flow Sens.	Reference ground is AGND
AGND	Analog Ground	--	Reference for Aout1, Dout1 and Dout2
RS485+	RS485 +	Fieldbus	Modbus protocol
RS485-	RS485 -		
NC	Do not connect	--	--
NC	Do not connect	--	--
Shield	Shielding	Shielding	To be connected to earth (see wire No. 2, P-)

Figure 9: Interface specifications of standard "OEM" model

Note 1: Power supply wire cross-section is 1.5 mm² and for signal wires 0.14 mm²

Note 2: For more detailed description of interfaces consult user manual

DIMENSIONS OF MAIN COMPONENTS

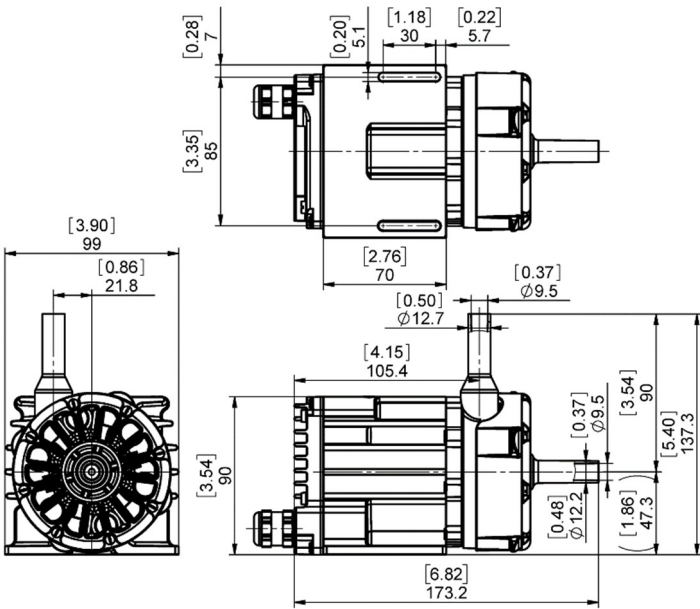

Pump Head
LPP-200.7

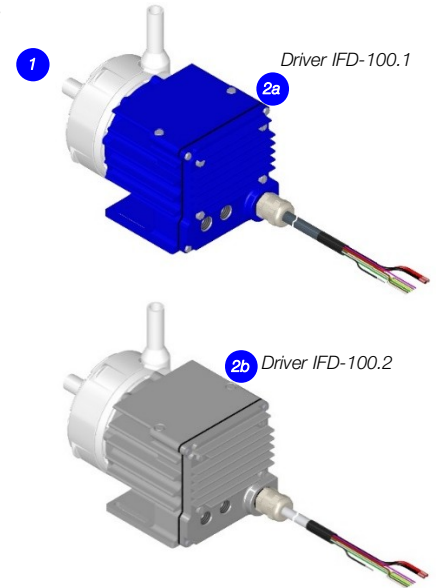
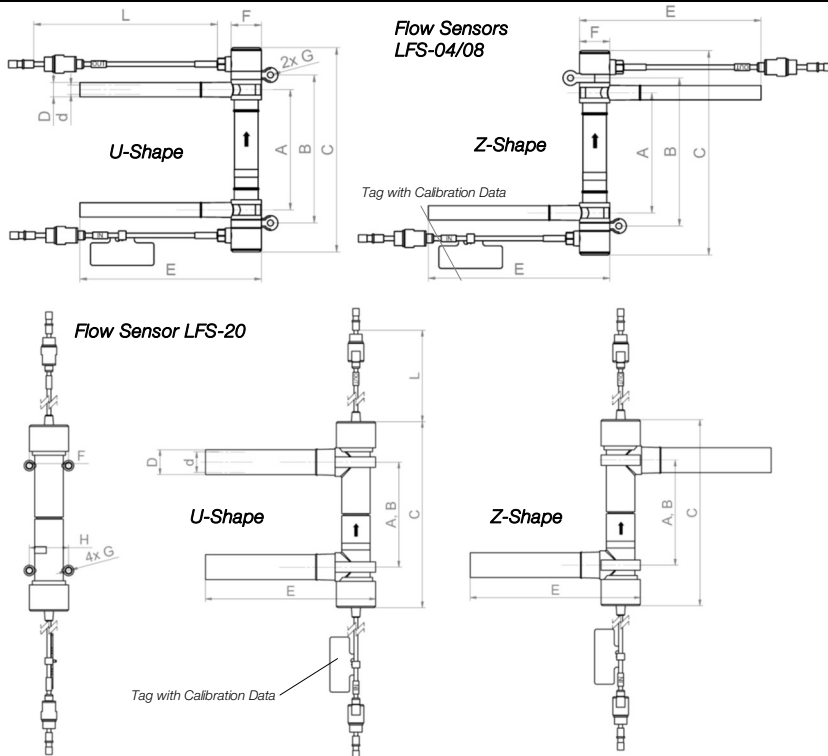

Figure 10: Basic dimensions and description of standard "OEM" model (Non-tolerated dimensions are for reference only)



Sensor	LFS-04	LFS-08	LFS-20
Tube Size	3/8"	3/8"	1/2"
A	80 ± 1	80 ± 1	80 ± 1
B	98.5 ± 1	98.5 ± 1	80 ± 1
C	136 ± 1	136 ± 1	136 ± 1
D	9.35	9.35	12.7
d	6.33	6.33	9.5
E	120	120	120
F	Ø 20	Ø 20	Ø 30
G	Ø 4	Ø 4	M4 x 30 (Z-shape) M4 x 31 (U-shape) Max torque = 0.3 Nm
H	--	--	25
L	500	500	500

Figure 11: Dimensions of flow sensor (dimensions in [mm])
(Non-tolerated dimensions are for reference only)

Characteristics	Flow Controller Type	BPS-IF100 for 4 l/min	BPS-IF100 for 8 l/min	BPS-IF100 for 20 l/min
Flow Range [µm]		0 – 4	0 – 8	0 – 20
Flow Velocity < 1 m/s	Flow Range [l/min] Accuracy of Read. / Repeatability	0 – 0.8 ± 0.008 / < 0.004	0 – 1.7 ± 0.017 / < 0.009	0 – 4.7 ± 0.047 / < 0.024
Flow Velocity > 1 m/s	Flow Range [l/min] Accuracy of Read. / Repeatability	0.8 – 4 ± 1% / < 0.5%	1.7 – 8 ± 1% / < 0.5%	4.7 – 20 ± 1% / < 0.5%
Response Time: Step from 10 – 90% of full scale.		< 1s ¹	< 1s ¹	< 2s ¹
Fluid Temperature / Ambient Temperature		10 – 90 °C (50 – 194 °F) / 0 – 40 °C (32 – 104 °F)		
Max. Fluid Pressure / Sound Speed / Kinematic Viscosity		0 – 0.5 MPa (0 – 5 bar, 0 – 72.5 psi) / 1000 – 2200 m/s / 0.3 – 40 mm ² /s (0.3 – 40 cSt)		
Wet Materials / Enclosure Classification		PFA for flow sensors and pump head / IP-65 for flow sensor and flow controller driver		

Table 1: Specifications of flow controller systems BPS-IF100 (All data based on water at 20 °C)

1: Values for the specific hydraulic circuit optimized flow control parameters. Standard settings are tuned for general flow control stability and may be higher.

ORDER INFORMATION

System Name	Article #	Flow Sensor	Flow Control Driver	Pump Head	Note
BPS-iF100.1-04Z or -04U BPS-iF100.1-08Z or -08U BPS-iF100.1-20Z or -20U	100-90877 or 78 100-90919 or 20 100-90921 or 22	LFS-04-Z or -U (4 l/min) LFS-08-Z or -U (8 l/min) LFS-20-Z or -U (20 l/min)	IFD-100.1-50-01 (Epoxy Coat., PVC Cable)	LPP-200.7	OEM models. Flow sensor extension cables to be ordered as separate article (see Table 5 Pos. 4). The flow sensors can not be connected to the flow control driver without extension cables.
BPS-iF100.2-04Z or 04U BPS-iF100.2-08Z or 08U BPS-iF100.2-20Z or 20U	100-90879 or 80 100-90923 or 24 100-90925 or 26	LFS-04-Z or -U (4 l/min) LFS-08-Z or -U (8 l/min) LFS-20-Z or -U (20 l/min)	IFD-100.2-50-01 (ETFE Coating, FEP Cable)		
BPS-iF100.4-04Z or -04U BPS-iF100.4-08Z or -08U BPS-iF100.4-20Z or -20U	100-91366 or 67 100-91368 or 69 100-91370 or 71	LFS-04-Z or -U (4 l/min) LFS-08-Z or -U (8 l/min) LFS-20-Z or -U (20 l/min)	IFD-100.8-50-01 (ATEX, ETFE Coating)	LPP-200.7	OEM models with ATEX/IECEX Flow sensor extension cables to be ordered as separate article (see Table 5 Pos. 5). The flow sensors can not be connected to the flow control driver without extension cables.

Table 2: Standard flow control system configurations
Note 1: Driver comes delivered with sensor calibration parameters stored in driver if ordered as set.

Pos.	Component	Article Name	Article #	Characteristics	Value / Feature
1	Pump Head	LPP-200.7	100-90708	Impeller / Pump Housing Sealing O-Ring In-/Outlet Fittings Max. Flow Max. Diff.-Pressure Max. Viscosity Max. Liquid Temp.	High purity PFA FFPM (FFKM) perfluorelastomer ¹ ½" tube 20 liters/min / 5.3 gallons/min 2 bar / 29 psi 20 cP 90°C (194°F) ³
2a	Integrated Flow Control Driver ("OEM" Models)	IFD-100.1-50-01 ¹ (Epoxy/PVC)	100-10079	Voltage, Power Housing	24 VDC ±10%, 100 W Epoxy or ETFE (corrosion resistant) coated Aluminum, waterproofed IP-65 ²
2b		IFD-100.2-50-01 ¹ (ETFE/FEP)	100-10080	Cable Interfaces Standard Firmware	PVC or FEP jacket, open wires, cable length 5 m PLC, RS485 with Modbus protocol and flow sensor J 1.48
2c	Integrated Flow Control Driver (ATEX "OEM" Model)	IFD-100.8-50-01 ¹ (ETFE/FEP, ATEX)	100-10152	Housing Cable ATEX Certification Standard Firmware	ETFE coated Aluminum, waterproofed IP-65 ² FEP jacket, open wires, cable length 5 m CE II 3G Ex ec h mc IIC T4 Gc / CE II 3D Ex h tc IIC T90°C Dc J 1.48

Table 3: Specification of standard components
Note 1: If ordered as spare part, calibration parameters of sensor have to be stored with Levitronix® Service Software. Note 2: Designed and tested for IP-67. Note 3: ATEX driver IFD-100.8 is certified for max. 70°C liquid temperature.

Pos.	Article Name	Article #	Shape	Flow Range	Fitting	Cable Jacket	Cable Length	Special Feature	Note
3a or b	LFS-04-Z or U	100-30304 or 05	Z or U	0 – 4 l/min	3/8"			All sensors have PVDF male connector cover for IP-65 protection.	Extension/adaptor cables needed to connect sensor to driver (see Table 5 Pos. 5).
3c or d	LFS-08-Z or U	100-30306 or 07	Z or U	0 – 8 l/min	3/8"	FEP	0.5 m		
3e or f	LFS-20-Z or U	100-30308 or 09	Z or U	0 – 20 l/min	1/2"				

Table 4: Standard flow sensors

Pos.	Component	Article Name	Article #	Characteristics	Value / Feature
4	Flow Sensor Extension Cable	LFE-A.3-05 (0.5 m) LFE-A.3-10 (1 m) LFE-A.3-30 (3 m) LFE-A.3-60 (6 m)	190-10299 190-10300 190-10301 190-10302	Cable Jacket and Connector Special Feature	PVC, PP and PVDF connector covers for IP-65 chemical protection. Flame retardant PVC white (UL VW-1 corresponds to EN-60332-1-2) Note: comes delivered in pairs.
5	Impeller Exchange Kit	IEK-200.4	100-90733	Impeller LPI-200.5 (A) Seal. O-Ring (B) Pump (C) / Motor Screws (D) Exchange Tool IET-1.1 (E)	PFA FFPM (FFKM), 50.52 x 1.78 mm 6x M4 x 16 mm / 8x M3 x 40 mm (stainless steel PTFE coated) POM-C
6	AC/DC Power Supply	TSP 180-124 (Traco)	100-40018	Voltage Output / Input Dimensions Certification or Standards	24 VDC with 120 W / 85 – 132 and 187 – 264 VAC (autoselect) 110 x 110 x 54 mm (mountable on DIN rail 35 mm) UL/cUL, CB, Semi F47
7	USB to RS485 Adaptor-TR Isolated	YN-485I-TR	100-30392	Structure/Design Purpose	USB connector (A) with termination resistor and cable with connector pair (B and C) for external RS485 wire connection. Magnetically isolated. Cable length is 2m. Included is a USB space saver cable (D). Communication over fieldbus of driver with PC
8	ATEX Cable Sealing System	ACS-A.1 (Roxtec)	100-90292	Sleeve (A) and Gasket (B) Frame (C) 2x Cable Module (D)	Stainless Steel and EPDM Roxylon (EPDM rubber) Roxylon (EPDM rubber) Note: Lubricant (E) and measurement plates (F) are included.
9	User Panel	LUI-B.1-01	100-30448	Interface / Housing Rating Standard Firmware	RS485 / IP65 A3.00
10	IPS Cable Signal 6 Wires	ICS-1.2-50 (5 m)	190-10346	Cable Material / Wires Connection In / Connection Out Main Purpose	PVC jacket / 6x 0.08 mm ² and shielding Screw type plug for open wire connection / Circular Hirose type Fieldbus connection of LUI-B.1
11	Water Cooling Module	WCM-i100.1	190-10474	Materials Motor Mounting Screws Cooling Flow Pressure Drop / Max. Pressure Purpose	PTFE coated stainless steel for cooling plate (A) and mounting screws (B). 2x M4x16, stainless steel PTFE coated Min. 0.5 l/min at ≤ 20 °C. In- and outlet are NPT 1/8" x 6.7mm. 20 mbar for 1 l/min cooling flow (for water at 20 °C) / 4 bar Driver cooling for higher liquid temperatures (see user manual).

Table 5: Specification of accessories

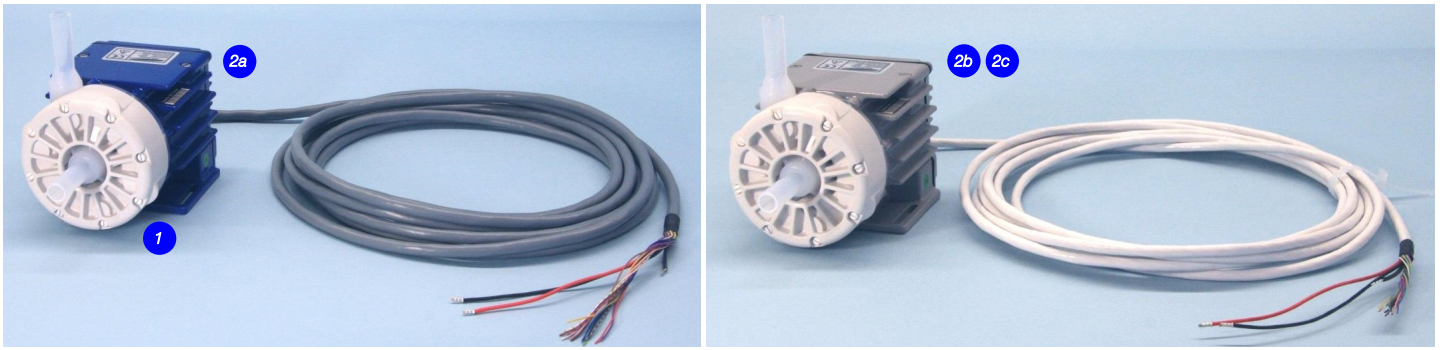

Figure 12: Standard flow control driver and pump head



Figure 13: Standard flow sensors and sensor extension cables



Figure 14: Accessories

Levitronix® is the world-wide leader in magnetically levitated bearingless motor technology. Levitronix® was the first company to introduce bearingless motor technology to the Semiconductor, Medical and Life Science markets. The company is ISO 9001 certified. Production and quality control facilities are located in Switzerland. In addition, Levitronix® is committed to bring other highly innovative products like the LEVIFLOW® flowmeter series to the market.



● LEVITRONIX®
● Representatives

Headquarter and European Contact

Levitronix GmbH
Technoparkstr. 1
CH-8005 Zurich
Switzerland

Phone: +41 44 974 4000
E-Mail: salesEurope@levitronix.com

US Contact

Levitronix Technologies Inc.
10 Speen Street, Suite 102
Framingham, Massachusetts 01701
USA

Phone: +1 508 861 3800
E-Mail: salesUS@levitronix.com

Japan Contact

Levitronix Japan K.K.
Wing Eight 5floor, 4-16-4
Asakusabashi, Taito-ku
Tokyo, 111-0053 Japan

Phone: +81 3 5823 4193
E-Mail: salesJapan@levitronix.com

Taiwan Contact

Levitronix Taiwan
5F, No. 251, Dong Sec. 1, Guang-
ming 6th Rd., Chu Pei City,
Hsin-Chu 302, Taiwan, R.O.C.

Phone: +886 3 657 6209
E-Mail: salesAsia@levitronix.com