

Ultrapure Fluid Handling Integrated Pump System Series



BPS-i30

Standard	1.5 bar (22 psi)	7.4 lpm (2 gpm)
High Pressure	2.8 bar (40 psi)	3.8 lpm (1 gpm)
High Flow	1.1 bar (16 psi)	14.7 lpm (3.9 gpm)

No Bearings. No Seals. No Contamination!

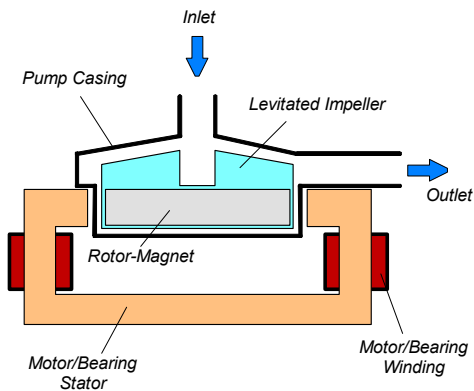

Figure 1: Schematic of the main elements of the MagLev centrifugal pump

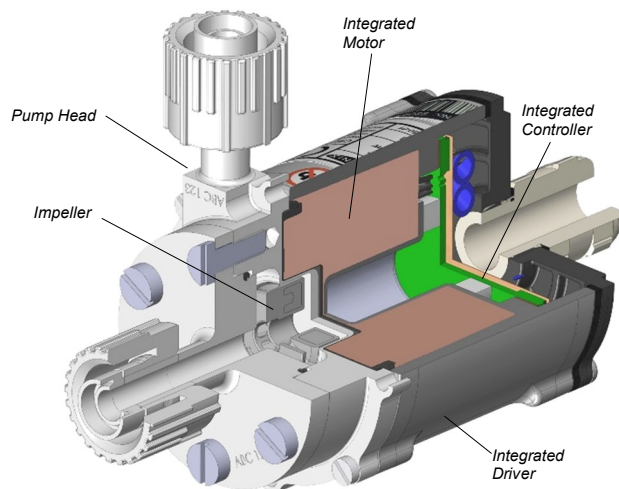

Figure 2: Integrated MagLev pump driver with pump head

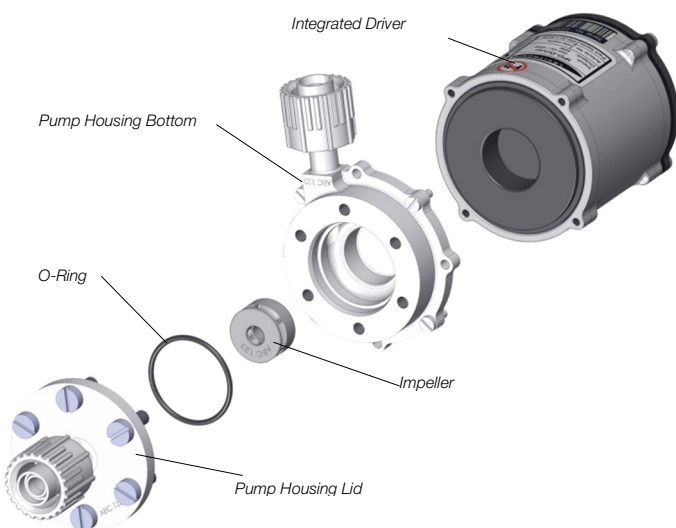

Figure 3: Disassembled pump head

INTRODUCTION

The *BPS-i30* pump system is a revolutionary centrifugal pump that has no bearings to wear out or seals to break down and fail. Based on the principles of magnetic levitation, the pump impeller is suspended, contact-free, inside a sealed casing and is driven by the magnetic field of the motor (*Figure 1*).

The impeller and casing are both fabricated from chemical-resistant high purity fluorocarbon resins. Together with the rotor magnet they make up the pump head.

The controller and the motor are integrated into the driver housing (see *Figure 2*), hence cabling effort is reduced. Fluid flow rate and pressure are precisely controlled by electronically regulating the impeller speed without pulsation.

SYSTEM BENEFITS

- Extremely low particle generation due to the absence of mechanically contacting parts.
- Increased equipment uptime.
- Lower maintenance costs by eliminating valves, bearings, rotating seals and costly rebuilds.
- Very low integration costs as no external controller is needed for speed or closed loop control.
- Reduced risk of contamination due to the self-contained design with magnetic bearings.
- Very gentle to sensitive fluids due to low-shear design.
- No narrow gaps and fissures where particles or microorganisms could be entrapped.
- Smooth, continuous flow without pressure pulsation.
- Electronic speed control.
- Compact design compared to pneumatic and mag-drive pumps.
- Proven technology in medical and semiconductor industry (MTBF > 50 years).

APPLICATIONS

- Semiconductor wet processing.
- Flip chip and advanced packaging.
- Solar cell production.
- Flat panel display manufacturing.
- Hard-disk fabrication.
- Printer ink handling.
- Pharmaceutical production.
- Plating.
- Circulation in flow batteries.

SYSTEM CONFIGURATION – “STAND-ALONE”

Figure 7 and Figure 12 illustrate a “Plug and Play” stand-alone system with integrated user panel and buttons to set the speed manually. The driver also contains a PLC interface for remote speed control by analog and digital signals. Various accessories are available like a desktop power supply with relevant power cable and signal cables to connect to the PLC.

SYSTEM CONFIGURATION – “EASYCONNECT”

The “EasyConnect” models (see Figure 10 and Figure 14) with according cable accessories are designed to realize various interface configurations with minimal setup effort. Two Fieldbus connectors (IN and OUT) allow to setup arrays of multiple pumps. Therefore, serial pumping configurations as shown in Figure 10 can be realized. The PLC interface allows not only remote control by analog/digital signals but also connections of external sensors hence enabling for example a precise flow or pressure control. The Fieldbus interface allows remote control over a PC, a User Panel or other devices with Modbus protocol. For enhanced chemical protection of the motor and cable connectors, protective connector covers (see Figure 19) are available.

SYSTEM CONFIGURATION – “OEM”

The “OEM” models are designed for a compact integration with one integrated driver cable containing all available interface signals (see Figure 8 and Figure 16). Basically, all configurations of the “EasyConnect” models are possible allowing the users with integration capabilities to adapt the cable to their needs.

PROCESS CONTROL WITH FEEDBACK SENSORS

Together with an external sensor, process parameters like flow or pressure can be controlled or monitored as shown in Figure 8. Precise ultrapure flow control systems can be realized with the BPS-i30 pump system in combination with LEVIFLOW® flowmeters. Levitronix® provides either turnkey solutions for closed loop flow control or helps to design your own flow control system. Experience has been gained with fluids such as CMP slurries, surface-conditioning chemicals, plating solutions, ultrapure water and solvents. The versatility of Levitronix® flow control systems goes far beyond the capabilities of simple flow controllers. In addition to the flow control function, the Levitronix® control firmware comes with several condition monitoring features to monitor the integrity of the fluid circuit. Levitronix® flow control systems can generate alarms for preventive filter exchange, no-flow conditions or line clogging. Dynamic Condition Trending (DCT) enables failure prediction and scheduling of preventive maintenance (Figure 6).

ATEX / IECEx SYSTEM CONFIGURATION

An ATEX / IECEx certified driver (OEM model only) together with the pump head allows installation within an ATEX Zone 2 area (see Figure 9). An Ex conform solution is needed for the motor cables to leave the ATEX area. One option is an ATEX certified cable sealing system as listed in Table 3 (see Pos. 12).

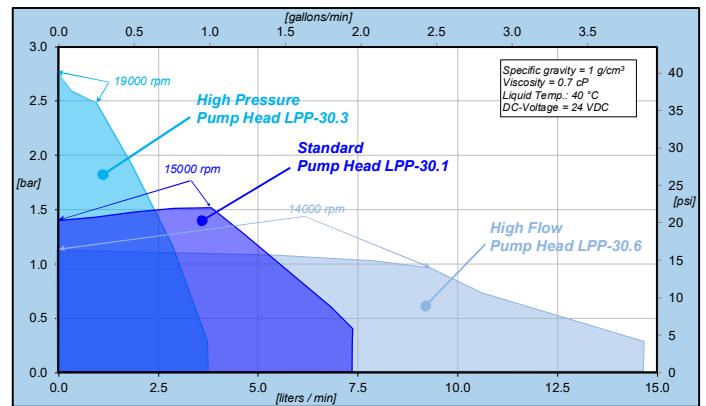

Figure 4: Pressure/flow ranges for pump head models (similar to water) (Standard, High Pressure and High Flow models)

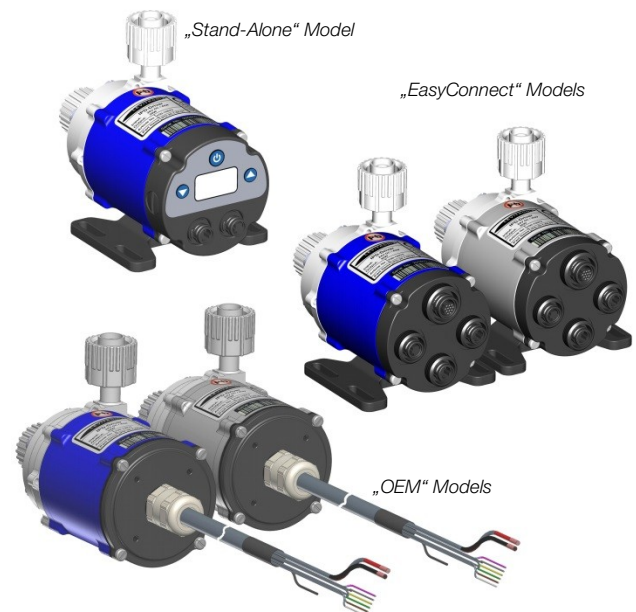

Figure 5: Pump system models

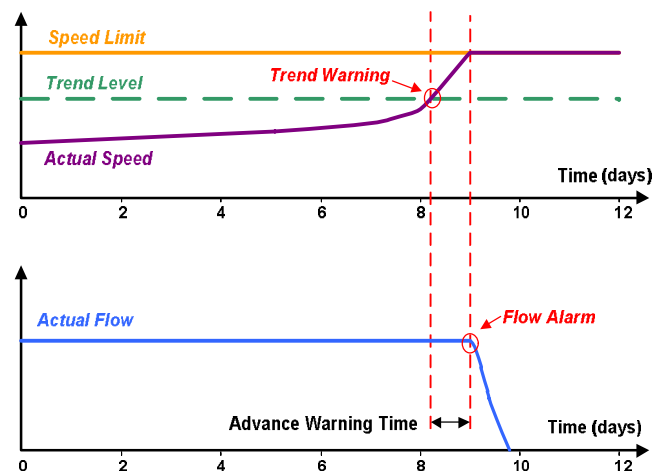

Figure 6: Dynamic Condition Trending (DCT)

SYSTEM CONFIGURATIONS

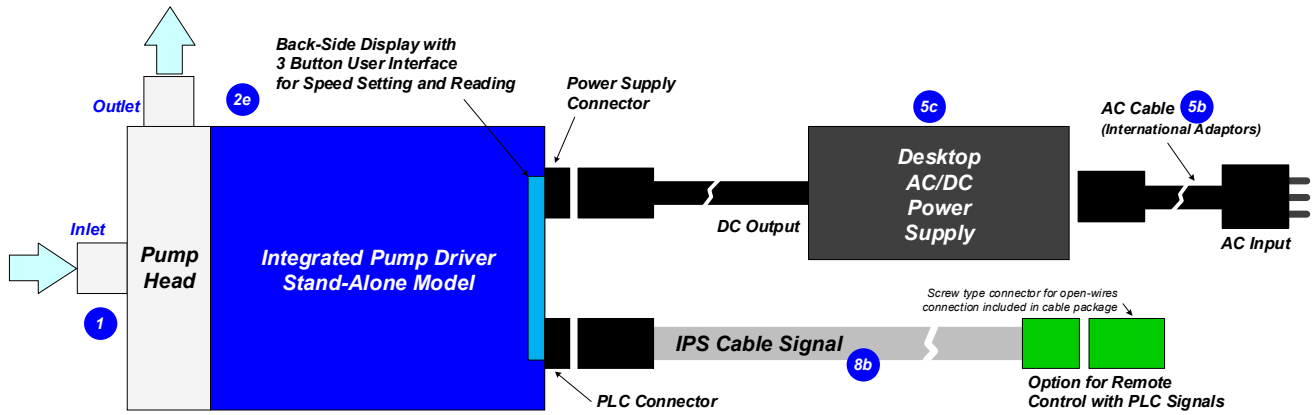

Figure 7: Standard "Stand-Alone" system configuration with main accessories
(See section "Order Information" for details to numbered components and other options)

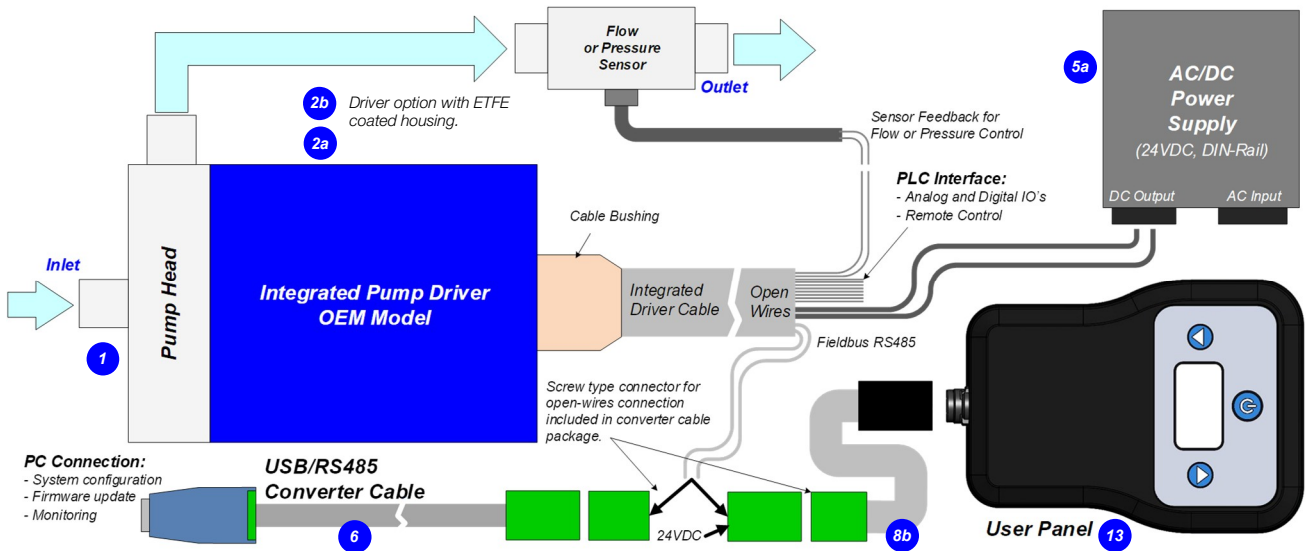

Figure 8: Standard "OEM" system configuration
(See section "Order Information" for details to numbered components and other options)

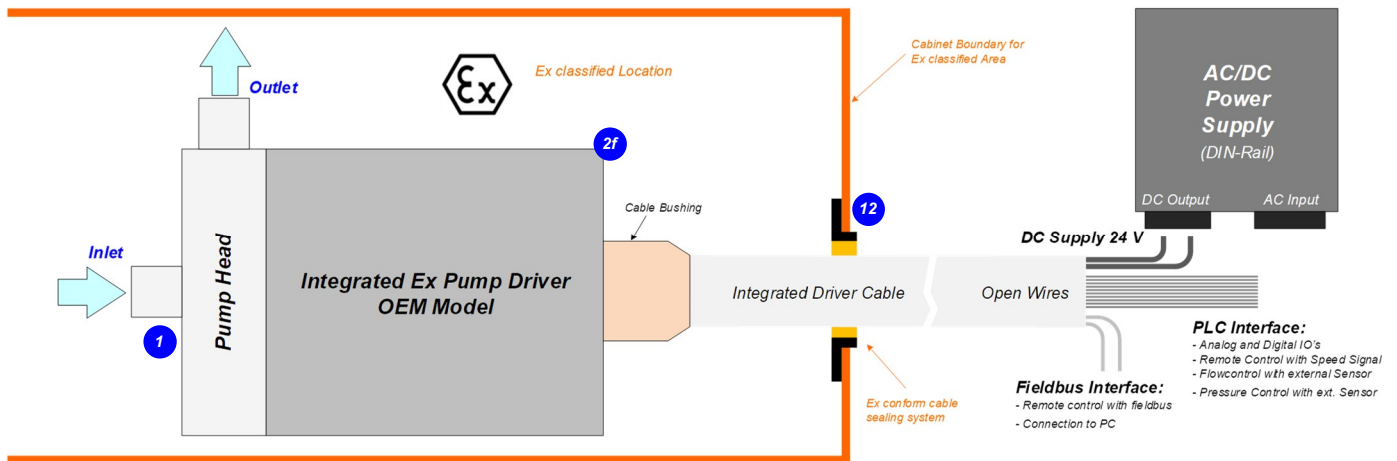

Figure 9: ATEX/IECEx "OEM" configuration
(See section "Order Information" for details to numbered components and other options)

SYSTEM CONFIGURATIONS

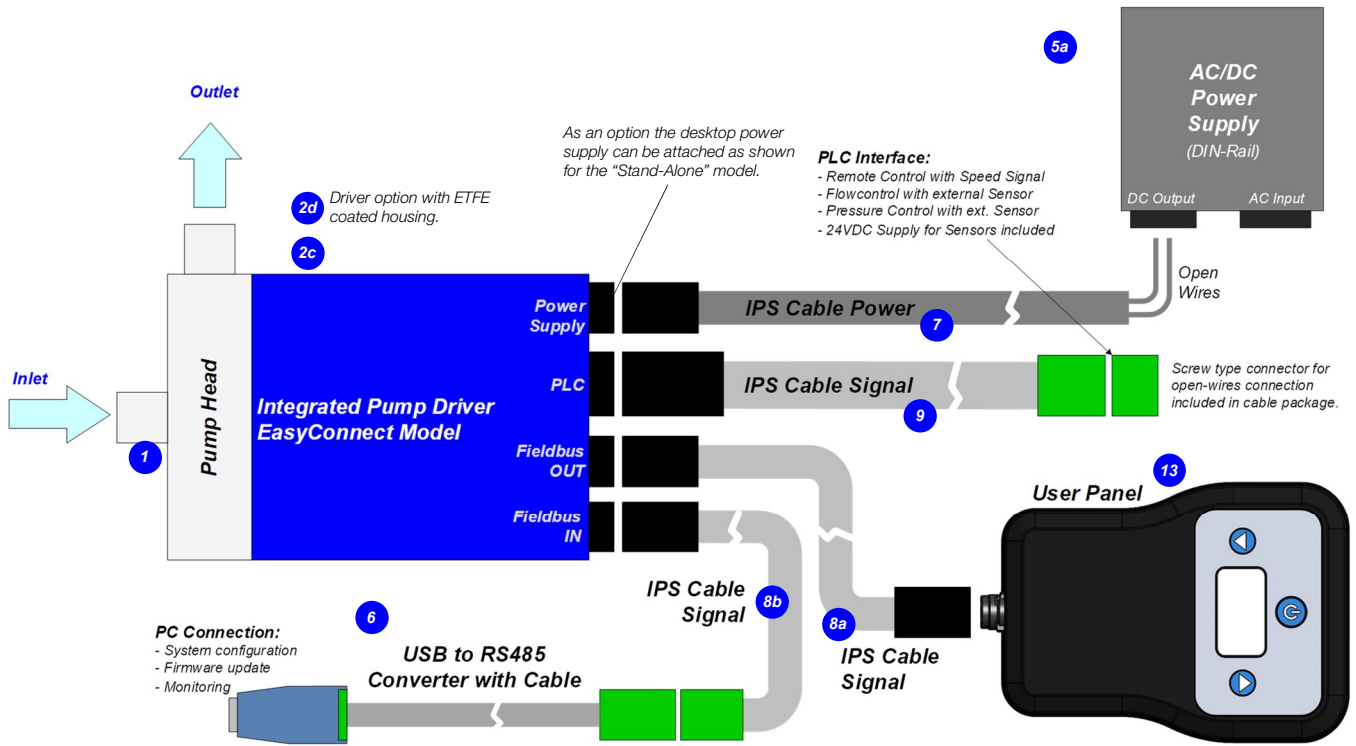

Figure 10: Standard "EasyConnect" system configuration with main accessories
(See section "Order Information" for details to numbered components and other options)

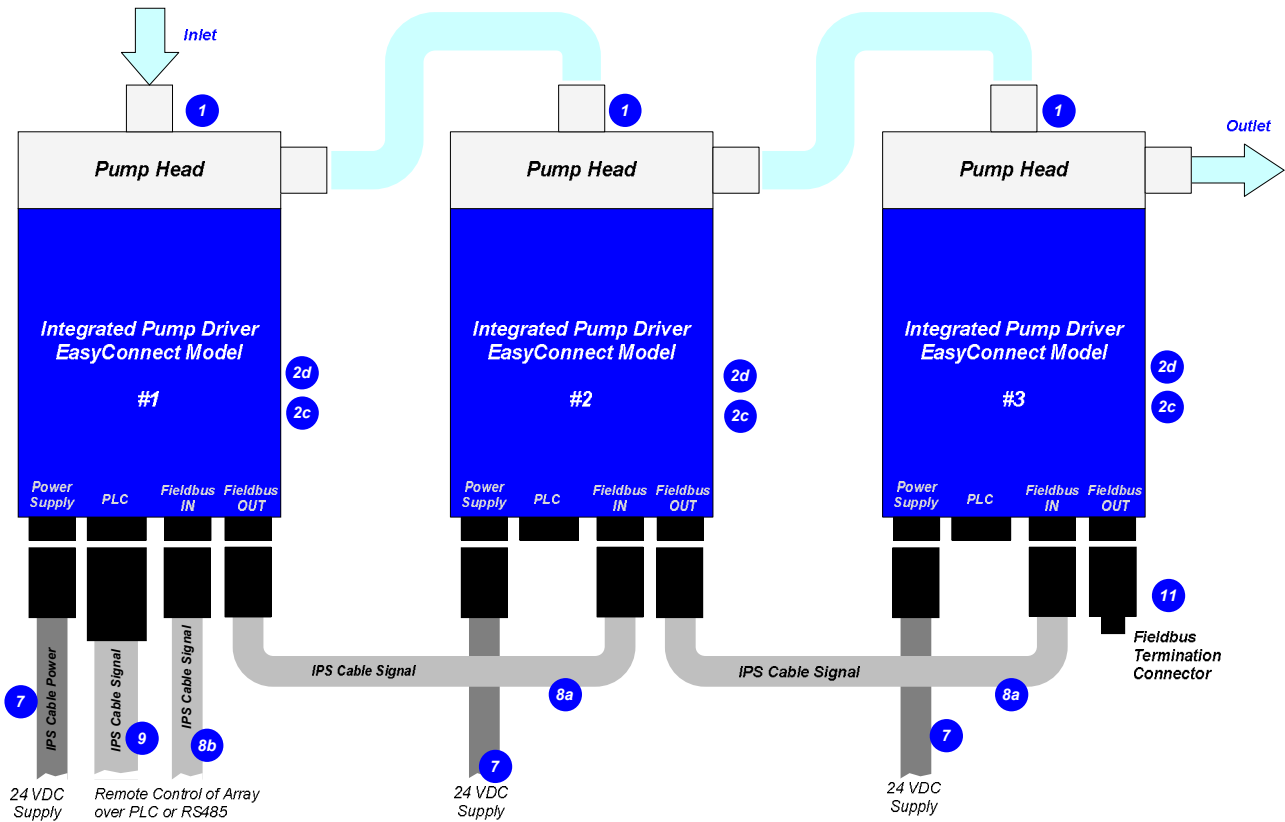
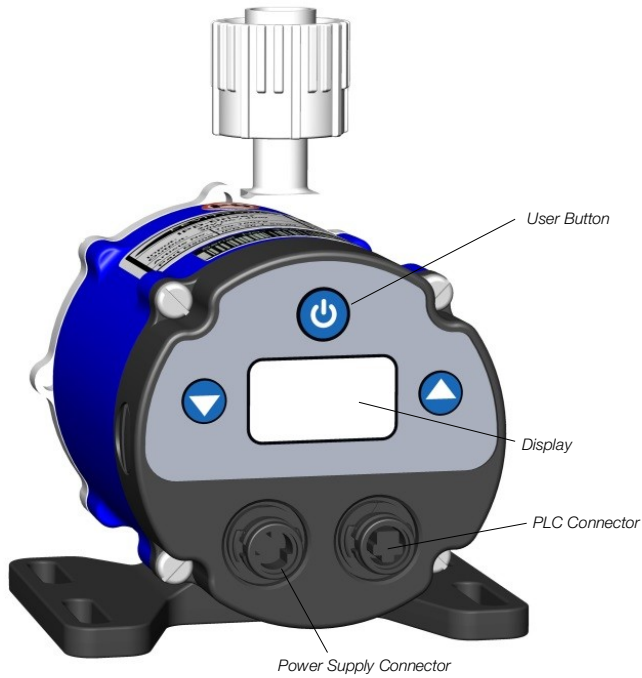

Figure 11: Serial pumping configuration with "EasyConnect" models
(See section "Order Information" for details to numbered components and other options)

MODEL DESCRIPTION – STAND-ALONE



Interface	PIN Name	Description	Standard Designation	Hardware Specification
Power Supply	P+	+ 24 VDC	Supply	Voltage: 24 VDC Power: 40 W
	P-	Power Input Ground / Earth		
	NC	Not connected.	--	--
PLC 6	Ain	Analog Input (Current Input)	Remote Speed	Analog current input: 4 – 20 mA (450 Ohm shunt input, no galvanic isolation)
	Ain_GND	Analog In. GND	--	Reference for Ain
	Dout	Digital Output 1	Status	Open drain, max. 24V, 100mA Reference ground is GND
	GND	Analog Ground	--	Reference for Dout
	Din1	Digital Input 1	Enable (Reset)	Galvanic separation with optocoupler 2.2 kΩ input resistance, 5-24V for active input
	Din_COM	Com. Digi. Input	--	Reference for digital input.
Display and Buttons	--	Display	Speed and Status Display	--
	--	Up/Down	Setting speed	--
	--	On/Off	Enable/Disable	--

Figure 12: Interface specifications of standard "Stand-Alone" model

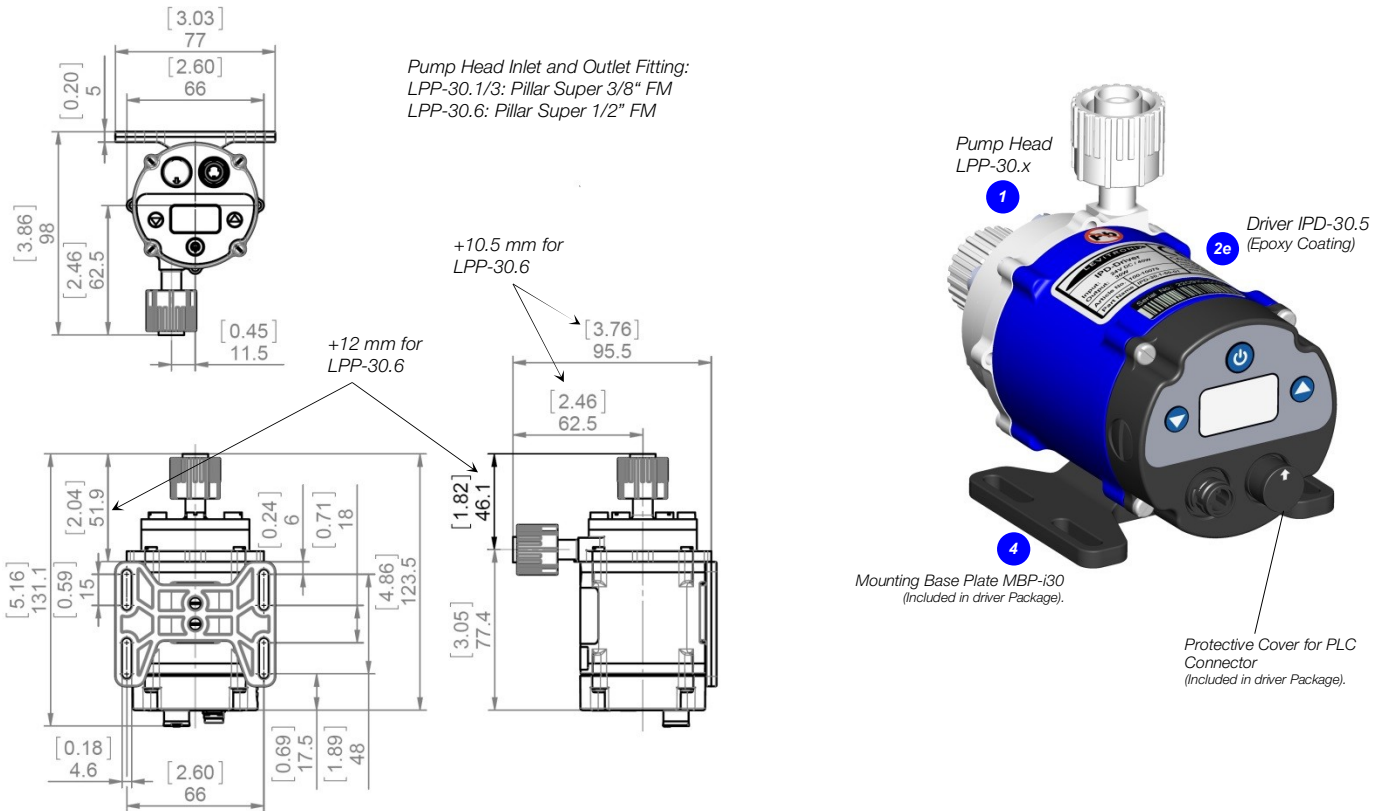
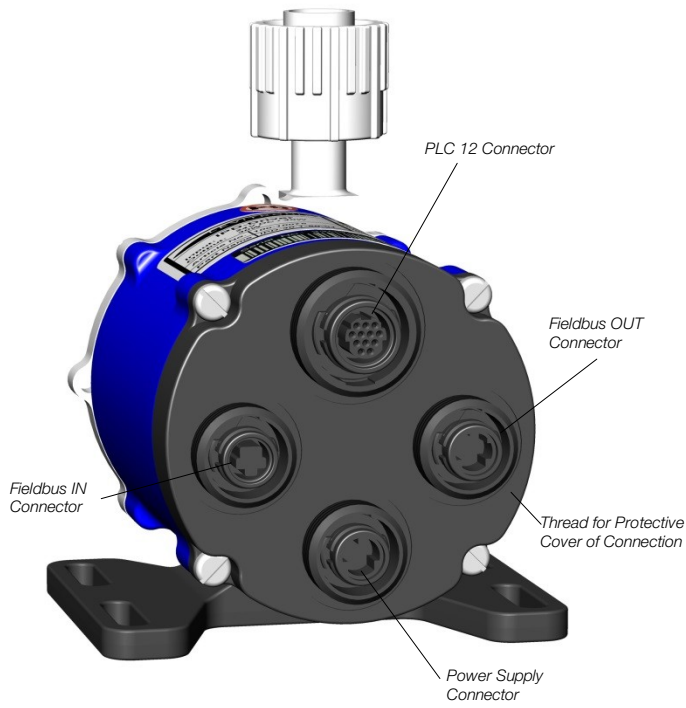

Figure 13: Basic dimensions and description of standard "Stand-Alone" model
Note 1: Non-tolerated dimensions are for reference only.

MODEL DESCRIPTION – EASYCONNECT



Connector	PIN Name	Description	Standard Designation	Hardware Specification
Power Supply	P+	+ 24 VDC	Supply	Voltage: 24 VDC
	P-	Ground / Earth		Power: 40 W
	NC	Not connected.	--	--
PLC 12	Dout1	Digital Output 1	Status	Open drain, max. 24V, 100mA
	Dout2	Digital Output 2	Error	Reference ground is GND
	Din1	Digital Input 1	Enable (Reset)	Galvanic separation with optocoupler
	Din2	Digital Input 2	Process Mode	2.2 kΩ input resistance, 5-24V for active input
	Din_COM	Com. Digi. Input	--	Reference for digital input.
	Ain1	Analog Input 1 (Current Input)	Actual Process Value	Analog current input: 4 – 20 mA (450 Ohm shunt input, no galvanic isolation)
	Ain2	Analog Input 2 (Voltage Input)	Reference Value	Analog voltage input: 0 – 10V (7.9 kOhm, no galvanic isolation)
	Ain_GND	Analog In. GND	--	Reference for Ain1 and Ain2
	Aout1	Analog Output (Voltage Output)	Actual Speed	0 – 10V (no galvanic isolation) GND is reference
	GND	Analog Ground	--	Reference for Aout1, Dout1, Dout2 and Pout
Fieldbus OUT	Pout	Output 24 VDC	Supply output	For supply of external devices (e.g. sensors) (Current 200 mA together with Pout of PLC 12)
	GND	Ground	--	Connected to GND and reference for supply
	Pout	Output 24 VDC	Supply Output	For supply of external devices (user panels) (Current 200mA together with Pout of PLC 12)
	RS485+	RS485 +	Field Bus	Modbus protocol
	RS485-	RS485 -	Field Bus	Modbus protocol
	Internal	Internal Bus	Do not connect	Internal bus needed to connect pumps for serial pumping.
	Internal	Internal Bus	Do not connect	Internal bus needed to connect pumps for serial pumping.
	GND	Ground	--	Connected to GND and reference for supply
	NC	Not connected.	--	--
	Fieldbus IN	RS485+	RS485 +	Field Bus
RS485-		RS485 -	Field Bus	Modbus protocol
Internal		Internal Bus	Do not connect	Internal bus needed to connect pumps for serial pumping.
Internal		Internal Bus	Do not connect	Internal bus needed to connect pumps for serial pumping.

Figure 14: Interface specifications of standard "EasyConnect" models

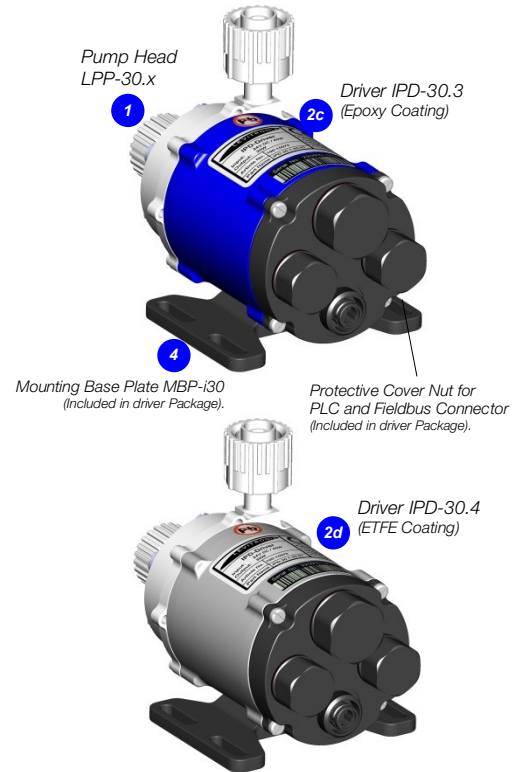
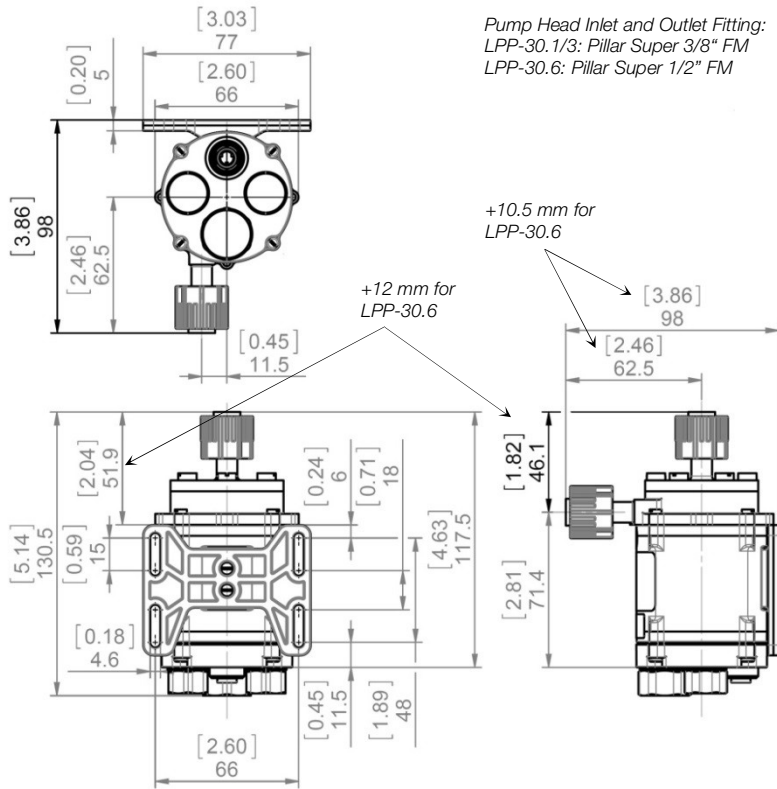
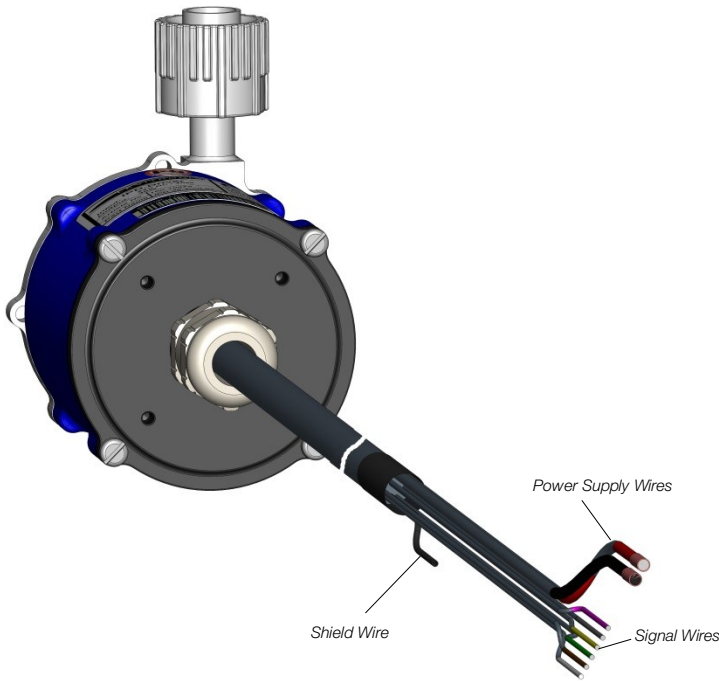

Figure 15: Basic dimensions and description of standard "EasyConnect" models
 Note 1: Non-tolerated dimensions are for reference only.



Wire Name	Description	Standard Designation	Hardware Specification
P+	+ 24 VDC	Supply	Voltage: 24 VDC P- to be connected to earth
P-	Power Input Ground / Earth		
Ain1	Analog Input 1 (Current Input)	Actual Process Value	Analog current input: 4 – 20 mA (450 Ohm shunt input, no galvanic isolation)
Ain2	Analog Input 2 (Voltage Input)	Reference Value	Analog voltage input: 0 – 10V (7.9 kOhm, no galvanic isolation)
Ain_GND	Analog Input Ground	--	Reference for Ain1 and Ain2
Din1	Digital Input 1	Enable (Reset)	Galvanic separation with optocoupler 2.2 kΩ input resistance, 5-24V for active input
Din2	Digital Input 2	Process Mode	
Din_COM	Common Digital Input	--	--
Aout1	Analog Output (Voltage Output)	Actual Speed	0 – 10V (no galvanic isolation) GND is reference
Dout1	Digital Output 1	Status	Open drain, max. 24V, 100mA
Dout2	Digital Output 2	Error	Reference ground is GND
GND	Analog Ground	--	Reference for Aout1, Dout1 and Dout2
RS485+	RS485 +	Field Bus	Modbus protocol
RS485-	RS485 -		
Internal	Internal Bus	Do not connect	For internal usage.
Internal	Internal Bus	Do not connect	For internal usage.
Shield	Shielding	Shielding	To be connected to earth (see wire No. 2, P-)

Figure 16: Interface specifications of standard "OEM" models

Note 1: Power supply wires are 1.5mm² and signal wires 0.14mm² Note 2: For more detailed description of interfaces consult user manual

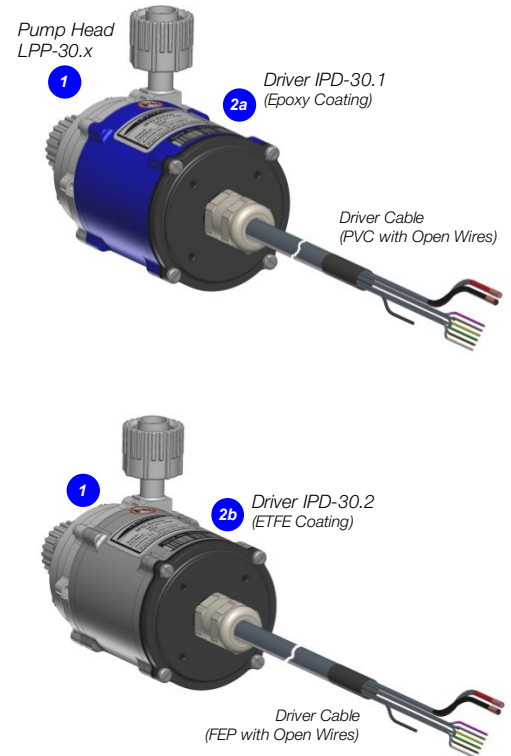
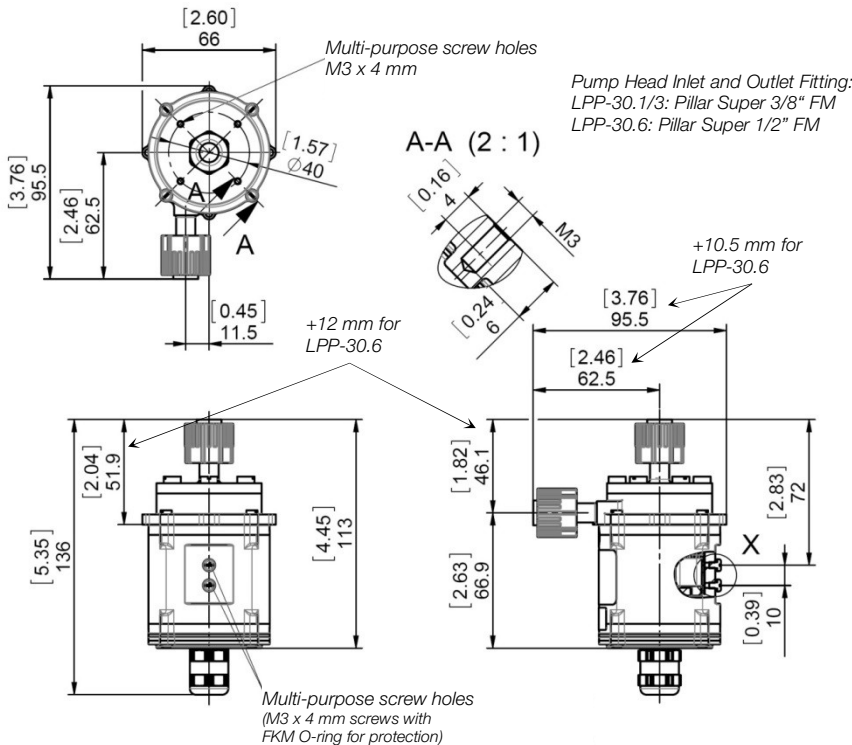

Figure 17: Basic dimensions and description of standard "OEM" models

Note 1: Non-tolerated dimensions are for reference only.

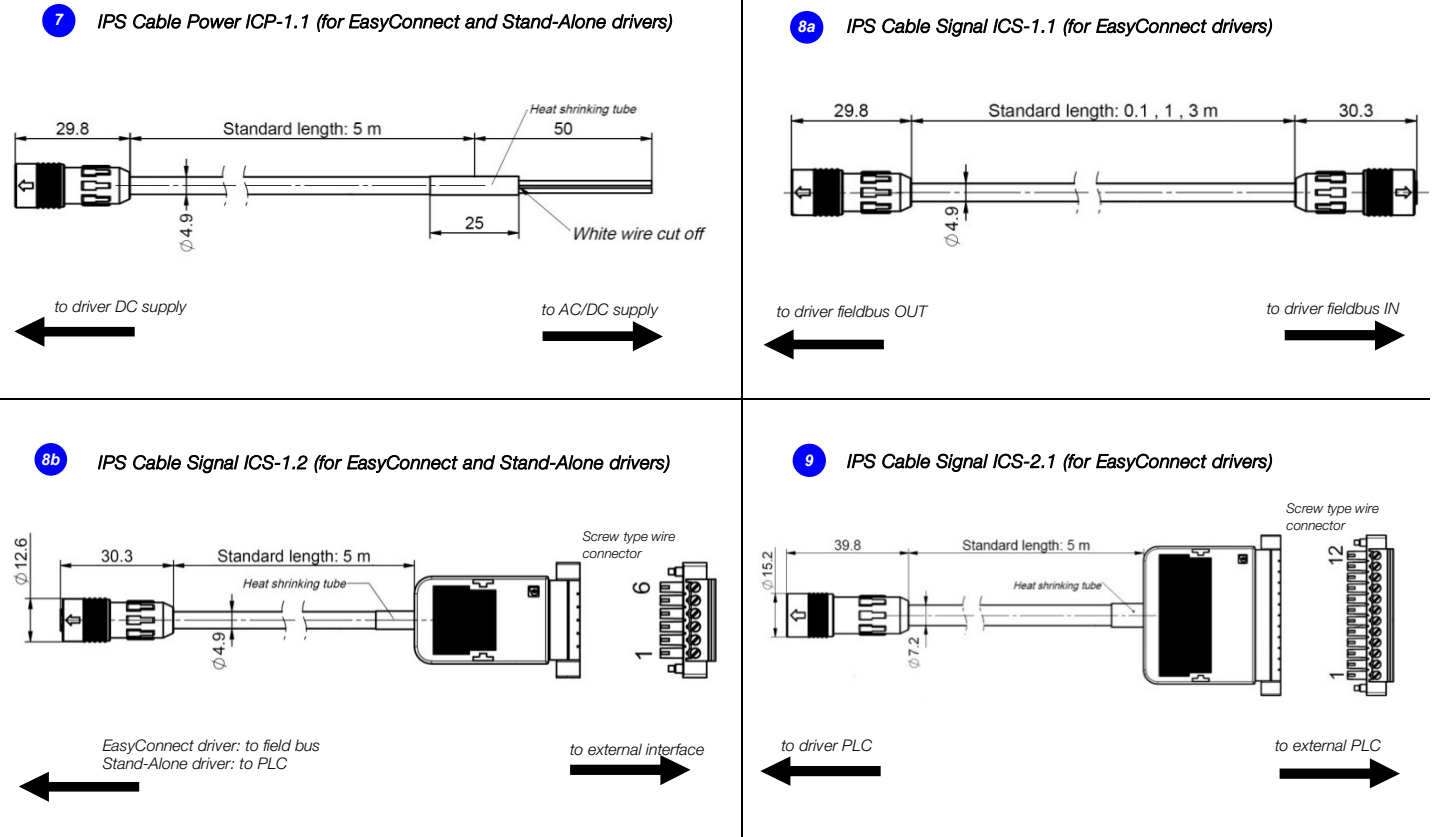

Figure 18: Basic dimensions and specifications of standard IPS cables
 Note 1: Non-tolerated dimensions are for reference only.

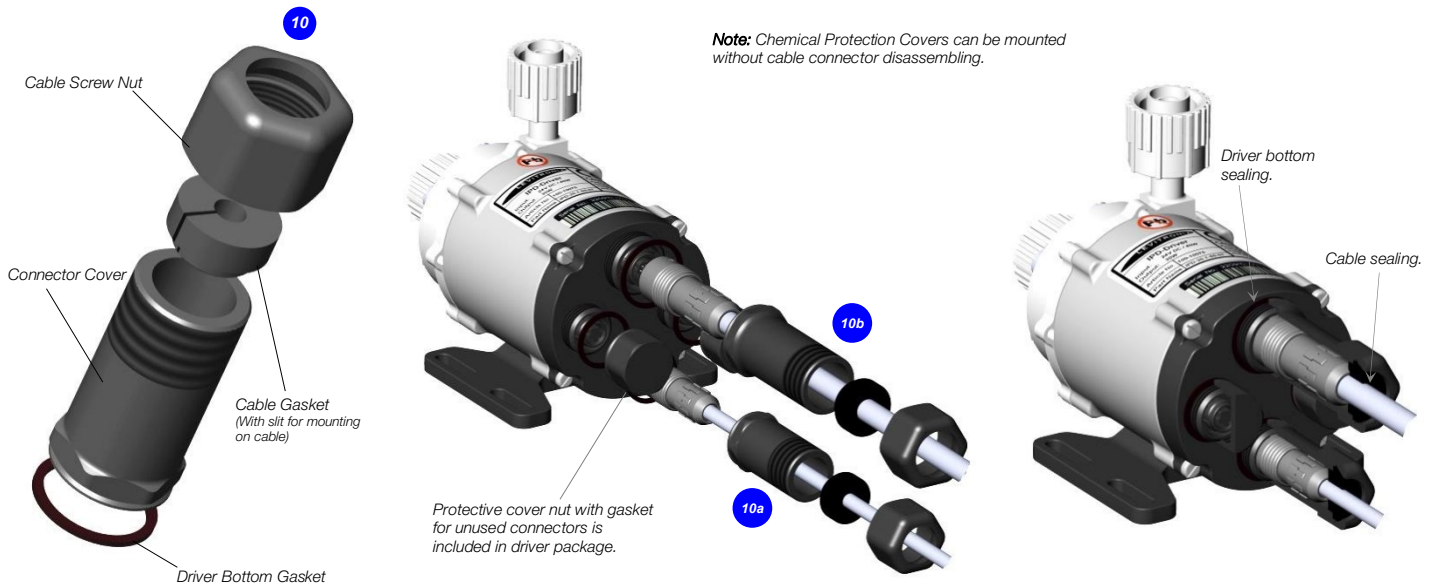

Figure 19: Basic concept of protective covers for enhanced chemical protection of driver connectors

ORDER INFORMATION

System Name	Article #	Pump Head	Driver	Note
BPS-i30.1 / 13 / 7	100-90831 / 91209 / 91187	LPP-30.1 / 3 / 6 ²	IPD-30.1-50-01 / 03 / 04	OEM - Epoxy coated driver, 5 m PVC cable with open wires, PTFE pump head.
BPS-i30.2 / 14 / 8	100-90832 / 91214 / 91189	LPP-30.1 / 3 / 6 ²	IPD-30.2-50-01 / 03 / 04	OEM - ETFE coated driver, 5 m FEP cable with open wires, PTFE pump head.
BPS-i30.20 / 21 / 22	100-91362 / 91363 / 91364	LPP-30.1 / 3 / 6 ²	IPD-30.12-50-01 / 03 / 04	ATEX, OEM - ETFE coated driver, 5 m FEP cable open wires, PTFE pump head.
BPS-i30.3 / 15 / 9	100-91022 / 91215 / 91188	LPP-30.1 / 3 / 6 ²	IPD-30.3-01 / 03 / 04 ¹	EasyConnect - Epoxy coated driver with interface connectors, PTFE pump head.
BPS-i30.4 / 16 / 10	100-91023 / 91216 / 91210	LPP-30.1 / 3 / 6 ²	IPD-30.4-01 / 03 / 04 ¹	EasyConnect - ETFE coated driver with interface connectors, PTFE pump head.
BPS-i30.5 / 17 / 11	100-90987 / 91217 / 91211	LPP-30.1 / 3 / 6 ²	IPD-30.5-01 / 03 / 04 ¹	Stand-Alone - Epoxy coated driver with integrated user panel, PTFE pump head.

Table 1: Standard system configurations

Note 1: Mounting Base Plate MBP-i30.1 included. Note 2: LPP-30.1 is "Standard", LPP-30.3 is "High Pressure" and LPP-30.6 is "High Flow" pump head.

Pos.	Component	Article Name	Article #	Characteristics	Value / Feature
1a	Pump Head	LPP-30.1 (Standard)	100-90828	Impeller / Housing / O-Ring In-/Outlet Fittings	PTFE / PTFE / FPM (FFKM) perfluorelastomer (a)+(b): 3/8" Pillar Super 300 FM (female) (c): 1/2" Pillar Super 300 FM (female)
1b		LPP-30.3 (High Pressure)	100-91213	Max. Flow	(a): 7.4 lpm (2 gpm) (b): 3.8 lpm (1 gpm) (c): 14.7 lpm (3.9 gpm)
1c		LPP-30.6 (High Flow)	100-91315	Max. Diff.-Pressure Max. Viscosity Max. Liquid Temp.	(a): 1.5 bar (22 psi) (b): 2.8 bar (40 psi) (c): 1.1 bar (16 psi) (a): 10 cP (b): 10 cP (c): 10 cP 90 °C (194 °F) ³
2a	Integrated Pump Driver ("OEM Models")	IPD-30.1-50-01 (Epoxy, Standard)	100-10075	Voltage, Power	24 VDC ±10%, 35 W
2b		IPD-30.1-50-03 (Epoxy, High Pressure)	100-10124	Housing	Epoxy (a) or ETFE (b) coated Aluminum, PP for bottom lid, IP65 ¹
2c		IPD-30.1-50-04 (Epoxy, High Flow)	100-10117	Cable	PVC (a) or FEP (b) jacket, open wires, cable length 5 m
2d	Integrated Pump Driver ("EasyConnect" Models) (MBP-i30.1 included)	IPD-30.2-50-01 (ETFE, Standard)	100-10076	Interfaces	PLC and RS485 with Modbus protocol (see Figure 16 for details)
2e		IPD-30.2-50-03 (ETFE, High Pressure)	100-10125	Standard Firmware	Standard pump head: H1.48 High Pressure: H3.48 High Flow: H4.48
2f		IPD-30.2-50-04 (ETFE, High Flow)	100-10121		
2g	Integrated Pump Driver ("Stand-Alone" Model) (MBP-i30.1 included)	IPD-30.3-01 (Epoxy, Standard)	100-10095	Housing	Epoxy (c) or ETFE (d) coated Aluminum, PP for bottom lid, IP65 ¹
2h		IPD-30.3-03 (Epoxy, High Pressure)	100-10126	Interfaces	2x Fieldbus RS485 with Modbus protocol, PLC and power supply
2i		IPD-30.3-04 (Epoxy, High Flow)	100-10118	Standard Firmware ²	Standard pump head: H1.48 High Pressure: H3.48 High Flow: H4.48
2j	Integrated Pump Driver ("Stand-Alone" Model) (MBP-i30.1 included)	IPD-30.4-01 (ETFE, Standard)	100-10096		
2k		IPD-30.4-03 (ETFE, High Pressure)	100-10127		
2l		IPD-30.4-04 (ETFE, High Flow)	100-10122		
2m	Integrated Pump Driver ("Stand-Alone" Model) (MBP-i30.1 included)	IPD-30.5-01 (Standard)	100-10092	Housing	Epoxy coated Aluminum, PP for bottom lid, IP65 ¹
2n		IPD-30.5-03 (High Pressure)	100-10128	Interfaces	User panel with 3 user buttons, PLC and power supply
2o		IPD-30.5-04 (High Flow)	100-10119	Standard Firmware	Standard pump head: H1.25 High Pressure: H3.48 High Flow: H4.48
2p	Integrated Pump Driver ATEX/IECEx ("OEM Models" only)	IPD-30.12-50-01 (ETFE, Standard)	100-10156	Housing	ETFE coated Aluminum, PP for bottom lid, IP65 ¹
2q		IPD-30.12-50-03 (ETFE, High Pressure)	100-10169	Cable	FEP jacket, open wires, cable length 5 m
2r		IPD-30.12-50-04 (ETFE, High Flow)	100-10170	ATEX / IECEx Marking	CE II 3G Ex ec h mc IIC T4 Gc / CE II 3D Ex h tc IIC T90°C Dc

Table 2: Specification of standard components

Note 1: Designed and tested for IP67. Note 2: Special firmware for serial pumping as one unit (Figure 10) available on request. Note 3: ATEX driver IPD-30.12 certified to run at max. 70°C liquid temperature.

Pos.	Component	Article Name	Article #	Characteristics	Value / Feature
3a	Impeller Exchange Kit	IEK-30.1 (Standard)	100-90837	Impeller Material / Type (A)	PTFE / (a): LPI-30.1 (b): LPI-30.4 (c): LPI-30.5
3b		IEK-30.3 (High Pressure)	100-91219	Sealing O-Ring (B)	O-Ring, FPM (FFKM) Dimensions: (a)+(b): 28.3 x 1.78 mm (c): 33.05 x 1.78 mm
3c		IEK-30.4 (High Flow)	100-91317	Pump Housing Screws (C) Pump Motor Screws (D) Exchange Tool IET-30.1 (E)	6 pieces, stainless steel PTFE coated, M5 x 14 mm 4 pieces, stainless steel PTFE coated, M3 x 10 mm POM-C
4	Mounting Base Plate	MBP-i30.1	190-10313	Material / Mounting Screws	PP + 30% GF / 2 pieces, stainless steel FEP coated, M3 x 10 mm
5a	AC/DC Power Supply	TPC 055-124 HR30 (Traco)	100-40014	Voltage Output / Input Basic Dimensions Certification or Standards	24 VDC with 55 W / 85 - 264 VAC, 47-63 Hz 45 x 90 x 96.5 mm (mountable on DIN rail 35 mm) UL, CSA, CB, Semi F47
5b	Desktop AC/DC Power Supply	AC/DC Power Supply VEC50US24 HR30 (HR30 Connector)	100-40015	Voltage Output / Input Basic Dimensions Safety Approvals Note	24VDC, 50 W / 90 - 264 VAC, 47-63 Hz 116 x 52 x 31 mm IEC60950-1, EN60950-1, UL/cUL60950-1 Connector for direct connection to power supply of driver with cable length 1.2m.
5c	AC Mains Cables (for Desktop power supply 5b)	AMC-1.1 (2 m) / AMC-1.2 (2.5 m) AMC-1.3 (2.5 m) / AMC-1.4 (2.5 m) AMC-1.5 (2.5 m)	190-10331 / 32 190-10333 / 34 190-10335	Country Country Country	US, Canada / Germ., Denm., Norway, Finland, Belgium, Netherland, Sweden, Austria PSE, Japan / Switzerland CE, United Kingdom
6	USB to RS485 Adaptor-TR Isolated	YN-485I-TR	100-30392	Structure/Design Purpose	USB connector (A) with termination resistor and cable (2m) with connector pair (B and C) for external RS485 wire connection. Magnetically isolated. Cable length is 2m. Included is a USB space saver cable (D). Communication over fieldbus of driver with PC
7	IPS Cable Power 3 Wires	ICP-1.1-50 (5 m)	190-10342	Cable Material / Wires Connection In / Out Main Purpose	PVC jacket / 3x 0.5 mm ² (only 2 wires used, 1 is cut) Open wires / Circular Hirose type to driver Connection of power supply to "Stand-Alone" and "EasyConnect" drivers
8a	IPS Cable Signal 6 Wires	ICS-1.1-01 (0.1 m) ICS-1.1-10 (1 m) ICS-1.1-30 (3 m)	190-10343 190-10344 190-10345	Cable Material / Wires Connection In / Out Main Purpose	PVC jacket / 6x 0.08 mm ² and shielding Circular Hirose type / Circular Hirose type Fieldbus connection between "EasyConnect" drivers (e.g. multi-pump arrays)
8b	IPS Cable Signal 6 Wires	ICS-1.2-50 (5 m)	190-10346	Cable Material / Wires Connection In / Out Main Purpose	PVC jacket / 6x 0.08 mm ² and shielding Connector with screw type plug for open wire connection / Circular Hirose type Fieldbus connection to "EasyConnect" drivers and to PLC of "Stand-Alone" drivers.
9	IPS Cable Signal 12 Wires	ICS-2.1-50 (5 m)	190-10347	Cable Material / Wires Connection In / Out Main Purpose	PVC jacket / 12x 0.14 mm ² and shielding Connector with screw type plug for open wire connection / Circular Hirose type General connection to PLC of "EasyConnect" drivers.
10a	Chemical Protection Connector Cover	CPC-1.1	190-10349	Materials, IP-Rating	PP+GF30 and FPM/FKM for sealing gaskets, IP65 ¹
10b		CPC-1.2	190-10350	Main Purpose of CPC-1.1	Chemical protection of driver connectors of ICP-1.x and ICS-1.x cables.
10c		CPC-1.5	190-10352	Main Purpose of CPC-1.2 Main Purpose of CPC-1.5	Chemical protection of driver connectors of ICS-2.x cables. Chemical protection of fieldbus termination connector FTC-1.1
11	Fieldbus Termination Connector	FTC-1.1	190-10348	Materials Main Purpose	PPS for connector housing and FPM for sealing. Termination of fieldbus.
12	ATEX Cable Sealing System (A-F)	ACS-A.1 (Roxtec)	100-90292	Sleeve (A) / Gasket (B) Frame (C) / 2x Cable Module (D)	Stainless Steel / EPDM Roxylon (EPDM rubber) / Roxylon Note: Lubricant (E) and measurement plates (F) are included.
13	User Panel	LUI-B.1-01	100-30448	Interface / Housing Rating Standard Firmware	RS485 / IP65 A3.00
14	Water Cooling Module	WCM-i30.2	190-10486	Materials Motor Mounting Screws Cooling Flow Pressure Drop / Max. Pressure Purpose	PTFE coated stainless steel for cooling plate (A) and mounting screws (B). 2 x M3x10, stainless steel PTFE coated Min. 0.4 l/min at ≤ 20 °C. In- and outlet are NPT 1/8" x 6.7mm. 10 mbar for 1 l/min cooling flow (for water at 20 °C) / 4 bar Driver cooling for higher liquid temperatures (see user manual).

Table 3: Specification of cables and other accessories

Note 1: Designed and tested for IP67.

ORDER INFORMATION



Figure 20: Pump systems with standard components



Figure 21: Standard accessories

Levitronix® is the world-wide leader in magnetically levitated bearingless motor technology. Levitronix® was the first company to introduce bearingless motor technology to the Semiconductor, Medical and Life Science markets. The company is ISO 9001 certified. Production and quality control facilities are located in Switzerland. In addition, Levitronix® is committed to bring other highly innovative products like the LEVIFLOW® flowmeter series to the market.



Headquarter and European Contact

Levitronix GmbH
Technoparkstr. 1
CH-8005 Zurich
Switzerland

Phone: +41 44 974 4000
E-Mail: salesEurope@levitronix.com

US Contact

Levitronix Technologies Inc.
10 Speen Street, Suite 102
Framingham, Massachusetts 01701
USA

Phone: +1 508 861 3800
E-Mail: salesUS@levitronix.com

Japan Contact

Levitronix Japan K.K.
Wing Eight 5floor, 4-16-4
Asakusabashi, Taito-ku
Tokyo, 111-0053 Japan

Phone: +81 3 5823 4193
E-Mail: salesJapan@levitronix.com

Taiwan Contact

Levitronix Taiwan
5F, No. 251, Dong Sec. 1, Guangming
6th Rd., Chu Pei City,
Hsin-Chu 302, Taiwan, R.O.C.

Phone: +886 3 657 6209
E-Mail: salesAsia@levitronix.com