

MagLev Fan Technology For Harshest Environments

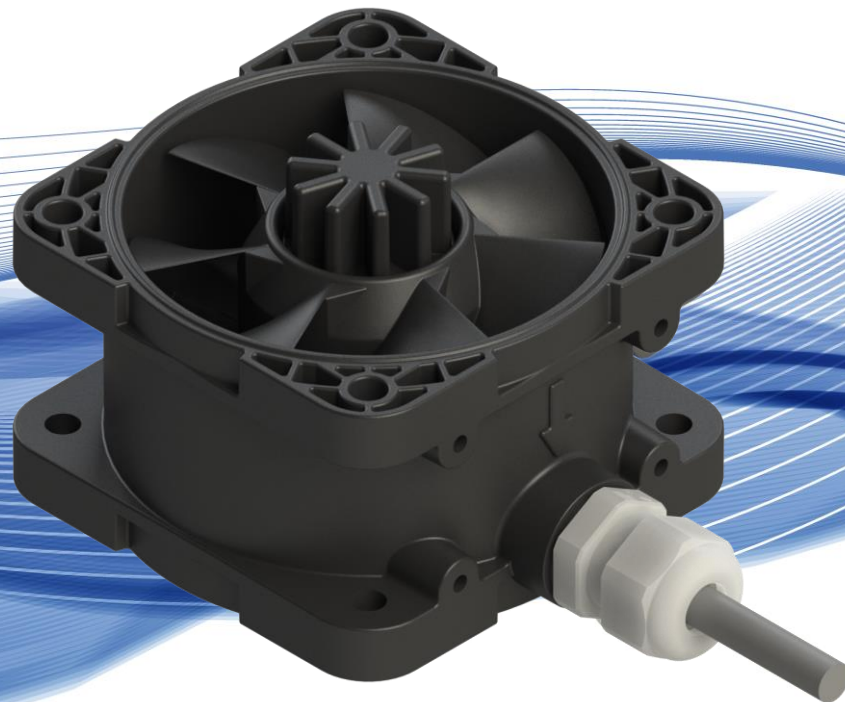

BFS-i04

870 Pa	(3.5 inH ₂ O)
4.4 m ³ /min	(155 cfm)

No Bearings. No Seals. No Problems.

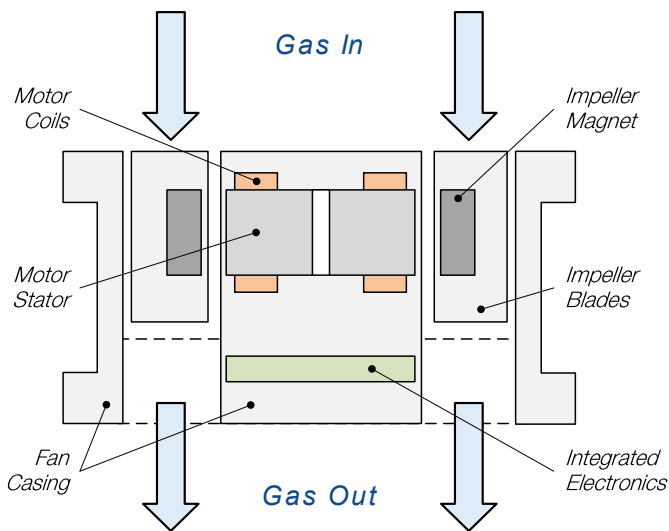

Figure 1: Schematic of the BFS-i04

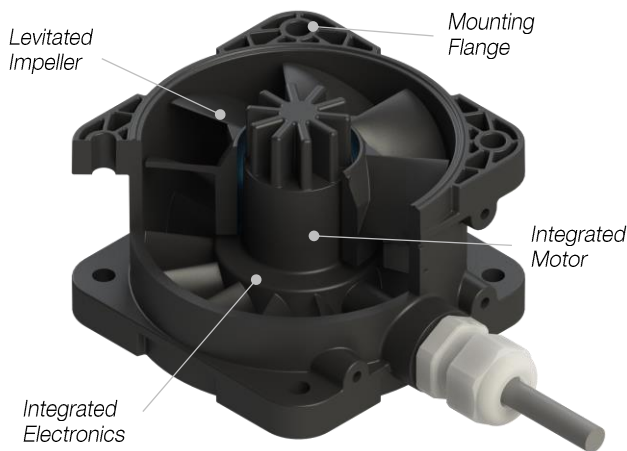

Figure 2: Components of the BFS-i04

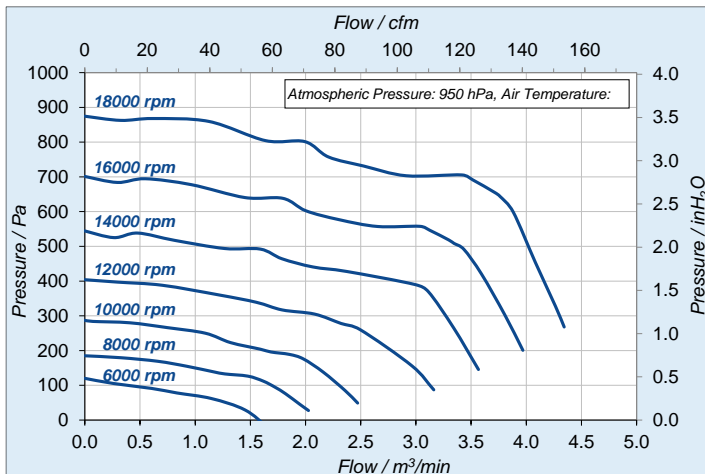

Figure 3: Pressure/flow curves (typical data for BFS-i04)

INTRODUCTION

Levitronix® has developed a revolutionary axial fan that has no bearings to wear out or seals to break down.

Based on the principles of magnetic levitation, the fan impeller is suspended and driven contact-free by the magnetic field of the bearingless motor (Figure 1).

Both impeller and casing are hermetically encapsulated in chemically resistant and electrically dissipative plastics (Figure 2), enabling safe operation in the harshest environments, including explosive atmospheres.

Flow rate, pressure and fan speed are precisely and quickly controlled by the integrated closed-loop controller, with PLC interface or RS485 bus with Modbus protocol.

BFS fans are an ultra-compact and power dense solution with minimal wiring requirements, thanks to high-speed operation and fully integrated motor and electronics.

SYSTEM BENEFITS

- Chemically resistant design for exposure to aggressive media.
- Certified for use in explosive atmospheres.
- Closed-loop flow or pressure control possible with additional sensor.
- Ultra-low particle generation and maintenance due to lack of bearings and dynamic seals.
- Hermetically sealed with single material in media contact - no safety or integrity concerns.
- Inline washdown with aggressive cleaning agents possible, e.g. to remove photo-resist deposits.
- Low vibration due to active unbalance compensation.

APPLICATIONS

- Exhaust control and boosting in semiconductor processing chambers and fabs.
- Gas flow control in coating and baking chambers.
- Flow control in ultra-pure environment.

INSTALLATION

The fans can be adapted to a wide variety of ducts. Multiple fans may be used in series to achieve higher pressure, or in parallel to achieve higher flow rate (Figure 4).

The interface panel *FIP-1.1* is available for easy wiring of multiple fans, for example:

- Individual control of up to four fans through a single power and fieldbus connection (Figure 5, left).
- Analog synchronization of two or more fans for parallel or serial operation (Figure 5, right).

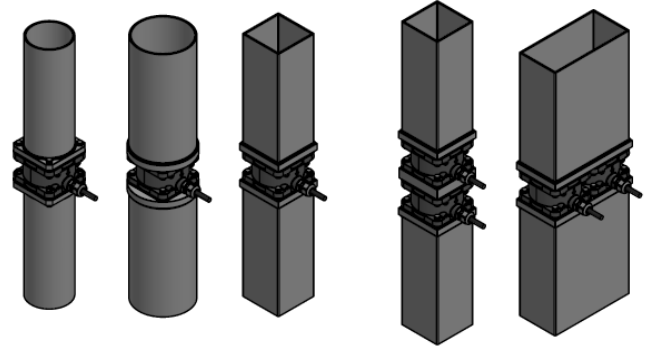

Figure 4: Example duct configurations

INTERFACES

Basic control is possible through the PLC interface:

- Speed control with one analog input.
- Closed loop process control with additional flow or pressure sensor on second analog input.
- Monitoring of actual speed or process value.

The RS485 bus offers full functionality including parameter logging, debugging and service, through one of the following means and for several fans at once (Figure 6):

- PC (*Levitronix® Service Software*).
- Handheld user panel *LUI-B.1*.
- Fieldbus (Modbus RTU protocol).

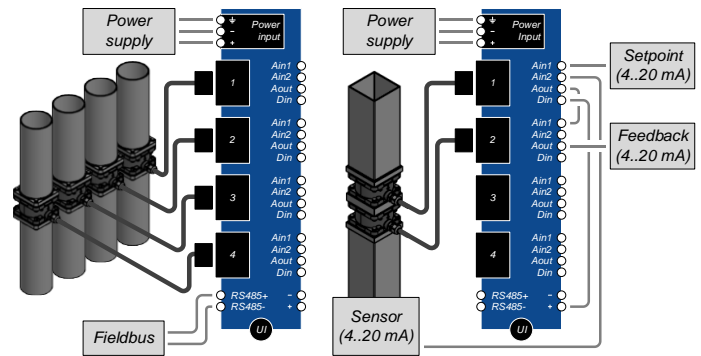



Figure 5: Example of interface panel setups

ATEX / IECEx RATING

The *BFS-i04.1* is ATEX / IECEx certified for installation in ATEX Zone 1 for gas or Zone 21 for dust. An Ex conform solution is needed for the motor cables to leave the ATEX area (e.g. a certified cable sealing, as in Table 2, Pos. 10).

- Ex marking of fan:



 II 2G Ex h mb IIC T6 Gb
 II 2D Ex h mb IIC T85 °C Db

- Max. allowed gas temperature is 40°C.
- Gas group IIC with T6 rating: all gases are allowed.

System configurations with interfacing options and accessories are shown in Figure 7 and Figure 8.

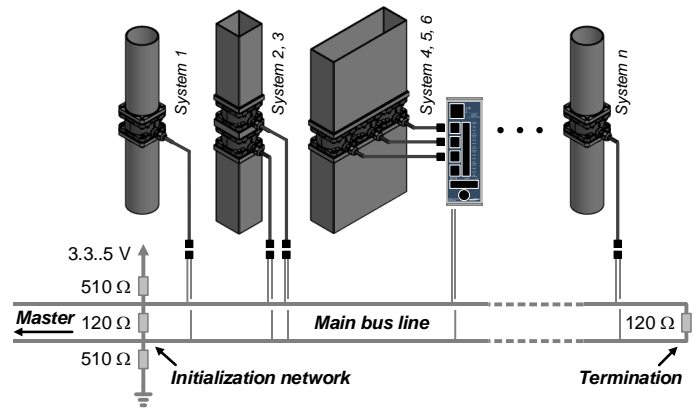

Figure 6: Multi-fan array on RS485 fieldbus

SYSTEM CONFIGURATIONS

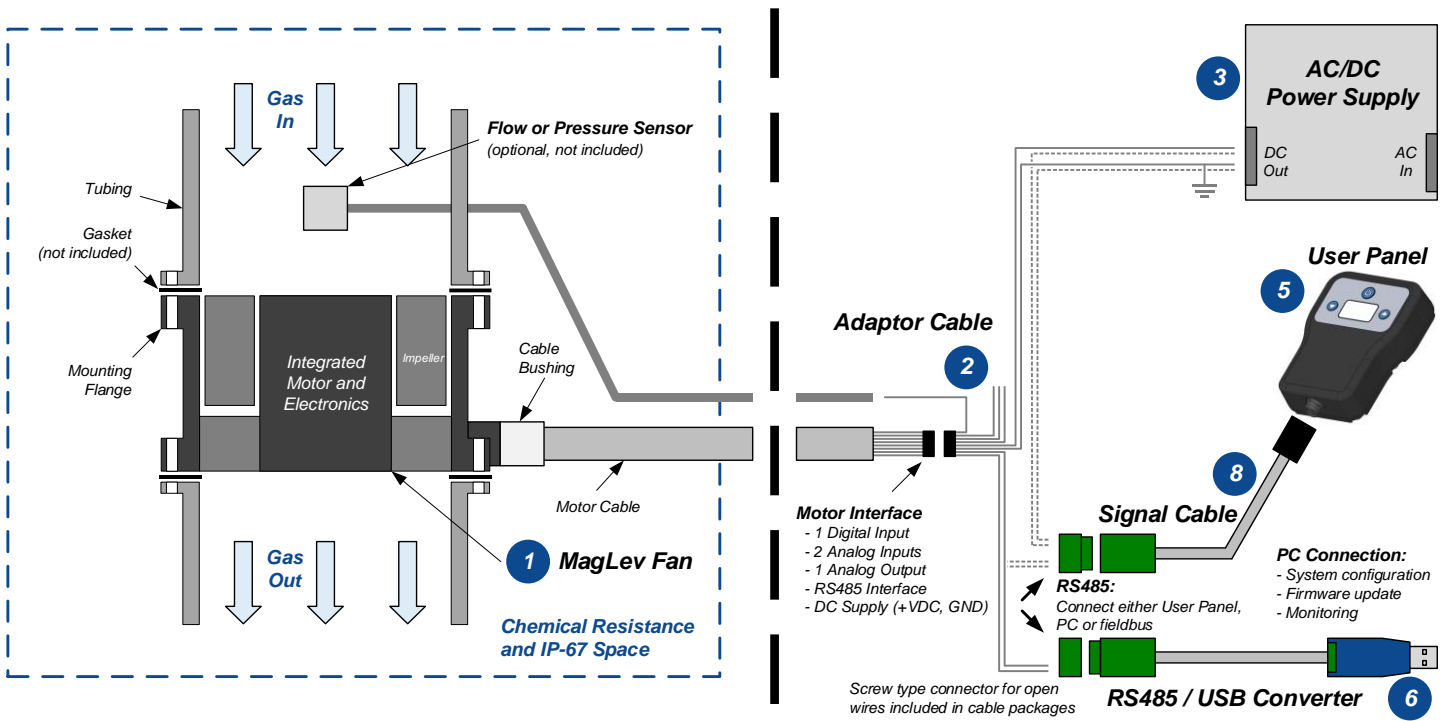

Figure 7: Standard system configuration (left) and possible connection with open wire adaptor (right)

Note: Connection options (right of dashed line) are interchangeable with Figure 8

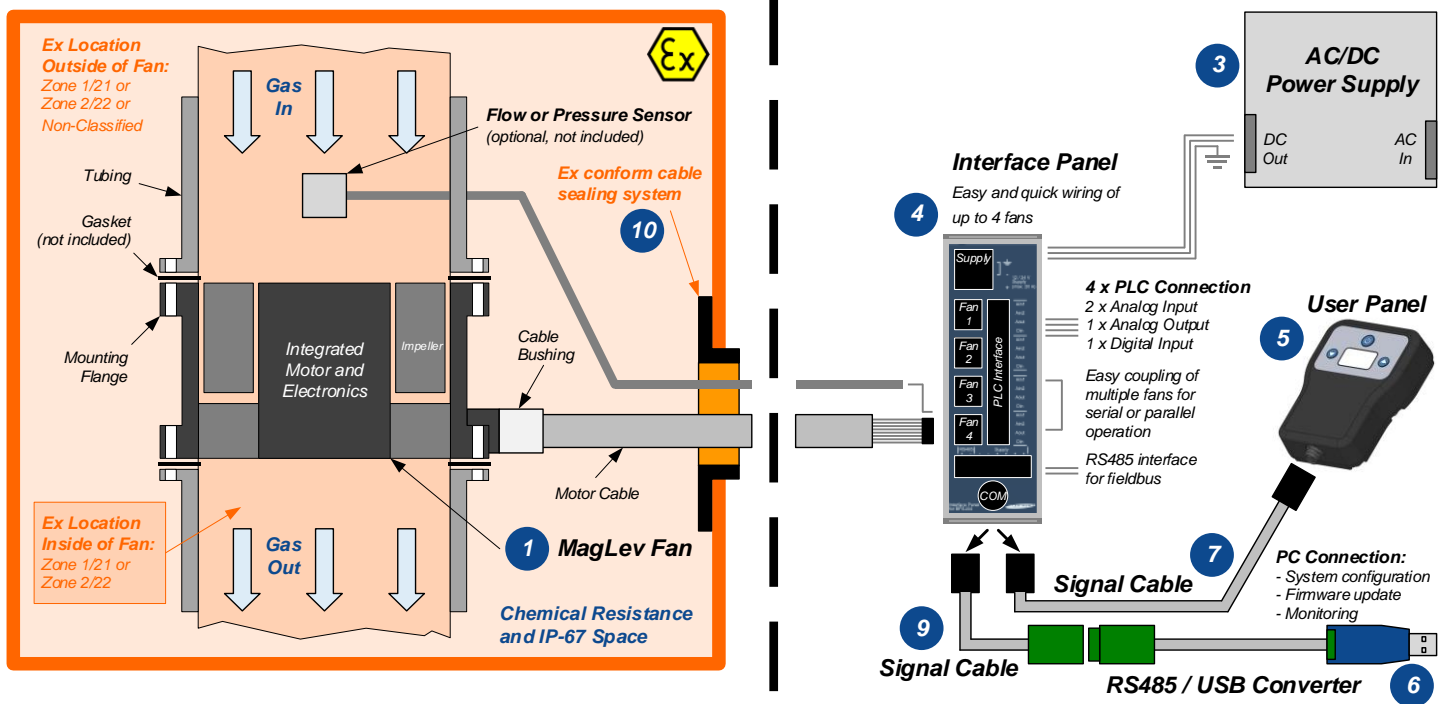
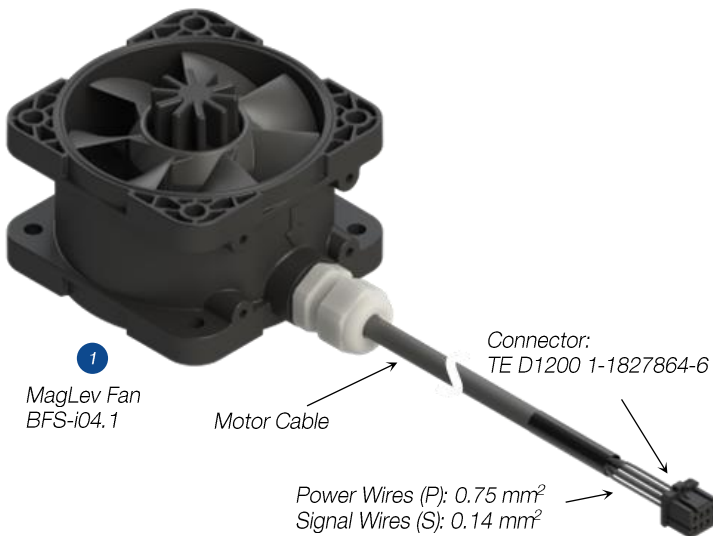
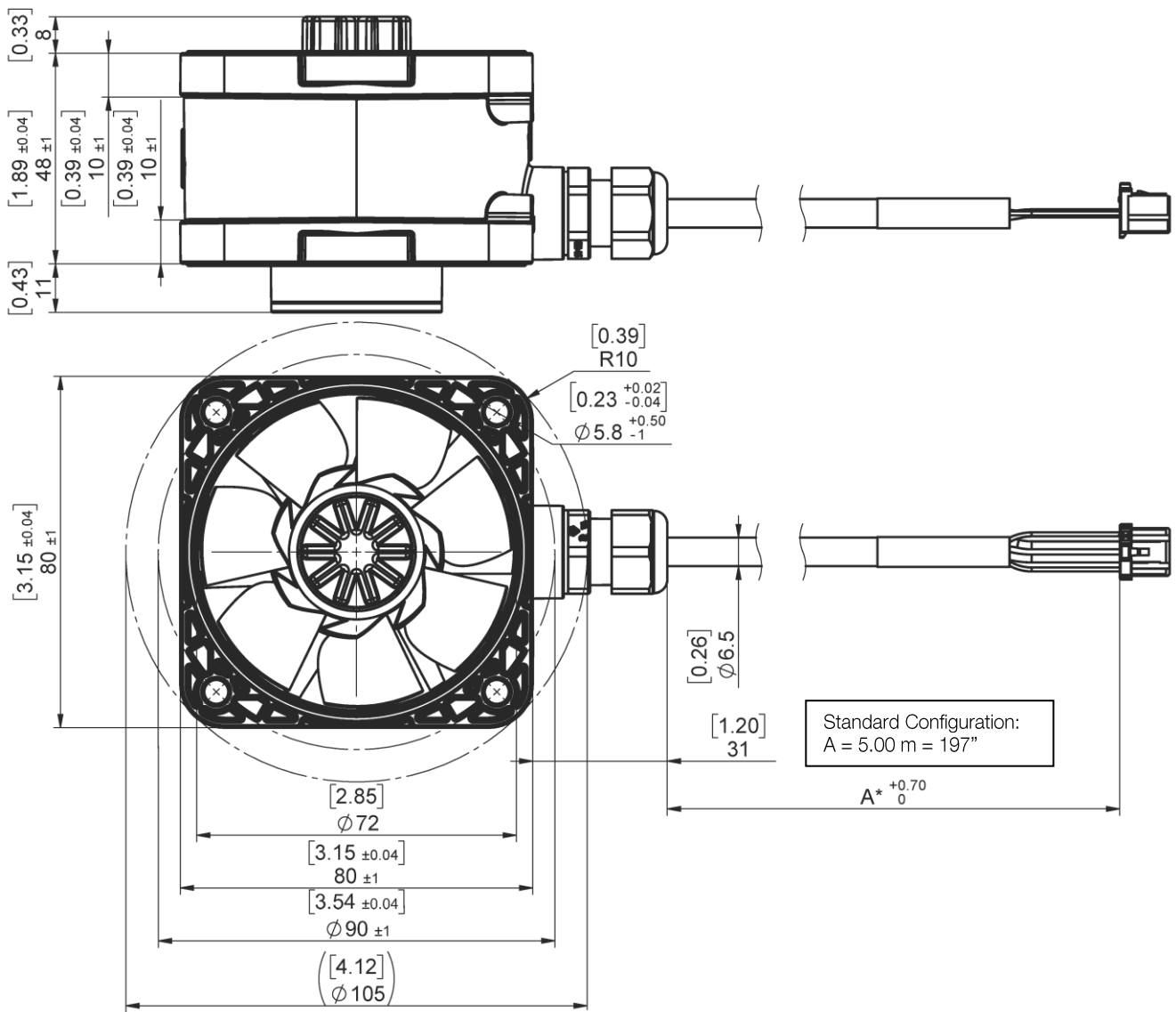

Figure 8: ATEX/IECEx system configuration (left) and possible connection with interface panel (right)

Note: Connection options (right of dashed line) are interchangeable with Figure 7

DIMENSIONS OF MAIN COMPONENTS



Pin	Wire Color	Designation	Description	Hardware Specification
P	A3 Red	Power +	Supply	Voltage: 24 VDC Power - to be connected to earth
	A2 Black	Power -		
B	B2 Pink	Analog input 1 (current input)	Setpoint speed or process value	Analog current input: 4 – 20 mA (240 Ω shunt input, no galvanic isolation) Reference is Power -
	B1 Gray	Analog input 2 (current input)	Actual process value (Pressure or flow sensor)	Analog current input: 4 – 20 mA (240 Ω shunt input, no galvanic isolation) Reference is Power -
S	B3 Blue	Digital input	Process mode	5 – 24 V for active input (127 kΩ input resistance, no galvanic isolation) Reference is Power -
	A1 Yellow	Analog output (current output)	Actual speed or process value	Analog current output: 4 – 20 mA (≤ 450 Ω shunt output, no galvanic isolation) Reference is Power -
A4 Brown	RS485 +	Fieldbus		Modbus protocol
A3 White	RS485 -			

Figure 9: Basic dimensions and interface description of BFS-i04 fan
Note: Non-tolerated dimensions are for reference only, dimensions in [inch] are rounded only

ORDER INFORMATION

Pos.	Component	Article Name	Article #	Characteristics	Value / Feature
1	Bearingsless Fan (ATEX / IECEx)	BFS-i04.1	100-10224	Voltage, Power Input	24 V DC $\pm 10\%$, 80 W (Option: 12 V DC $\pm 5\%$, 20 W, with reduced max. speed of 10000 rpm)
				Max. Pressure, Max. Flow	870 Pa (3.5 inH ₂ O), 4.4 m ³ /min (155 cfm)
				Point of Max. Power	700 Pa, 3.7 m ³ /min, 18000 rpm (optional 12 V supply voltage: 200 Pa, 2 m ³ /min, 10000 rpm)
				ATEX / IECEx Marking	 II 2G Ex h mb IIC T6 Gb II 2D Ex h mb IIIC T85 °C Db
					Ambient and gas temperature range 0 to 40 °C
				IP Rating	IP67
				Electrical Interfaces	PLC with 2 analog inputs 4-20 mA 1 analog output 4-20 mA 1 digital inputs 0-24 V
					RS485 interface, Modbus protocol (extended control or service through fieldbus or Levitronix® Service Software)
				Standard Firmware	V5.48
				Mechanical Interface	Flange on both motor sides with mounting holes 4 x Ø 5.8 mm on diameter 90 mm. Flange inside Ø 72 mm, outside 80 x 80 mm
				Cable Length	5 m with TE connector for power and PLC signals
Materials	Polypropylene, electrically conductive, flame retardant. Cable: PVC jacket, PVDF bushing				
Weight	0.5 kg, 1.1 lb				

Table 1: Specification of standard configuration

Pos.	Component	Article Name	Article #	Characteristics	Value / Feature
2	Adaptor Cable Hybrid	ICH-5.1-03 (0.3 m)	190-10544	Specifications Purpose	PVC insulated open wires (2 x 0.75 mm ² for power, 6 x 0.14 mm ² for signals) with TE connector Connection of fan cable to DC power supply and PLC signals
3	Compatible AC/DC Power Supply	TIB 080-124 †	To be ordered at Traco Electronic	Voltage Output / Input Power Output Certification or Standards	24 VDC / 85 – 265 V AC (full range) / 24 V DC 80 W (120 W for 4 s) CB, UL, CSA, Semi F47
4	Interface Panel	FIP-1.1	100-91638	Structure/Design Purpose	DIN-rail mountable PCB with connectors for: - 4 x BFS-i04 fans (TE Connectivity 1-1827875-4) - 1 x Power supply connector (Wago 2624-3103) - 18 x PLC push-in (analog input/ outputs, digital inputs, RS-485) - 1 x Circular COM for LUI-B.1 or RS485 to USB Converter Easy wiring of power and PLC signals for up to four BFS-i04 fans
5	User Panel	LUI-B.1-06	100-30649	Specifications Purpose	Firmware A8.00, IP65, 5 to 24 V supply voltage Control of fan via handheld device with display and menu buttons
6	USB-RS485 Adaptor	YN-485I-TR	100-30392	Structure/Design Purpose	USB connector (A) with termination resistor and cable (2 m) with connector pair (B and C) for external RS485 wire connection. Magnetically isolated. Included is a USB space saver cable (D) Control or service of fan via USB port of a PC with Levitronix® Service Software
7	IP Adaptor Cable Signal 6 Wires	ICS-1.1-10 (1 m) ICS-1.1-30 (3 m)	190-10344 190-10345	Specifications Purpose	PVC jacket, connectors: circular to circular type Connection of user panel (LUI-B.1) to interface panel (FIP-1.1)
8	IP Adaptor Cable Signal 6 Wires	ICS-1.2-10 (1 m) ICS-1.2-50 (5 m)	190-10440 190-10346	Specifications Purpose	PVC jacket, connectors: circular type to screw type Connection of user panel (LUI-B.1) to adaptor cable (ICH-5.1) and 5 to 24 V supply
9	IP Adaptor Cable Signal 6 Wires	ICS-1.3-50 (5 m)	190-10389	Specifications Purpose	PVC jacket, connectors: circular type to screw type Connection of interface panel (FIP-1.1) to USB adaptor (YN-485I-TR)
10	ATEX Cable Sealing System	ACS-A.1 (Roxtec)	100-90292	Materials Note	Sleeve (A) and Gasket (B): Stainless Steel, EPDM Frame(C) and 2x Cable Module (D): Roxylon (EPDM Rubber) Lubricant (E) and measurement plates (F) are included

Table 2: Specification of standard accessories

Note 1: See user manual for other compatible power supplies



Figure 10: Standard fan



Figure 11: Accessories

Levitronix® is the world-wide leader in magnetically levitated bearingless motor technology. Levitronix® was the first company to introduce bearingless motor technology to the Semiconductor, Medical and Life Science markets. The company is ISO 9001 certified. Production and quality control facilities are located in Switzerland. In addition, Levitronix® is committed to bring other highly innovative products like the LEVIFLOW® flowmeter series to the market.



Headquarter and European Contact

Levitronix GmbH
Bändliweg 30
CH-8048 Zurich
Switzerland

Phone: +41 44 974 4000
E-Mail: salesEurope@levitronix.com

US Contact

Levitronix Technologies LLC
10 Speen Street, Suite 102
Framingham, Massachusetts 01701
USA

Phone: +1 508 861 3800
E-Mail: salesUS@levitronix.com

Japan Contact

Levitronix Japan K.K.
Wing Eight 5floor, 4-16-4
Asakusabashi, Taito-ku
Tokyo, 111-0053 Japan

Phone: +81 3 5823 4193
E-Mail: salesJapan@levitronix.com

Taiwan Contact

Levitronix Taiwan
5F, No. 251, Dong Sec. 1,
Guangming 6th Rd., Chu Pei City,
Hsin-Chu 302, Taiwan, R.O.C.

Phone: +886 3 657 6209
E-Mail: salesAsia@levitronix.com

This document and its content are the property of Levitronix® and shall not be reproduced, distributed, disclosed or used for manufacturing or sale of Levitronix® products without the expressed written consent of Levitronix®.